

Bridging the Gap

This a troll tree zone! Right?

Day 1 & 2: Getting the Spin on Spin!

Think about the places you have been in the past month. Is it possible to get to many of these places without crossing a bridge? Many people in our area, around the country, and across the world live near a steep valley, river, stream, or lake, and bridges were built to keep communities connected across these boundaries.

Across gulfs and rivers, between peoples and countries, bridges break down separation and foster connectedness. (Option: Have students watch



and analyze the award winning short film *Le Gouffre* ([The Chasm](#)). A powerful tale about friendship, sacrifice and conquering the impossible. It is **strongly recommended** that you **must** watch it prior to showing it to your students to gauge its appropriateness for your class, their ages, and sensibilities. It has some

serious & sad elements & not every film is appropriate for every group.) After watching take time to analyze the bridge, the building strategies, and the character's choices. Ex. The villagers are full of hope and elation at the end. How do we as the viewers feel? Why?)

There are more than half a million bridges in the United States, and you rely on them every day to cross obstacles like streams, valleys, and railroad tracks. But do you know how they work? Or why some bridges are curved while others are straight? Engineers must consider many things -- like the distance to be spanned and the types of materials available -- before determining the size, shape, and overall look of a bridge.

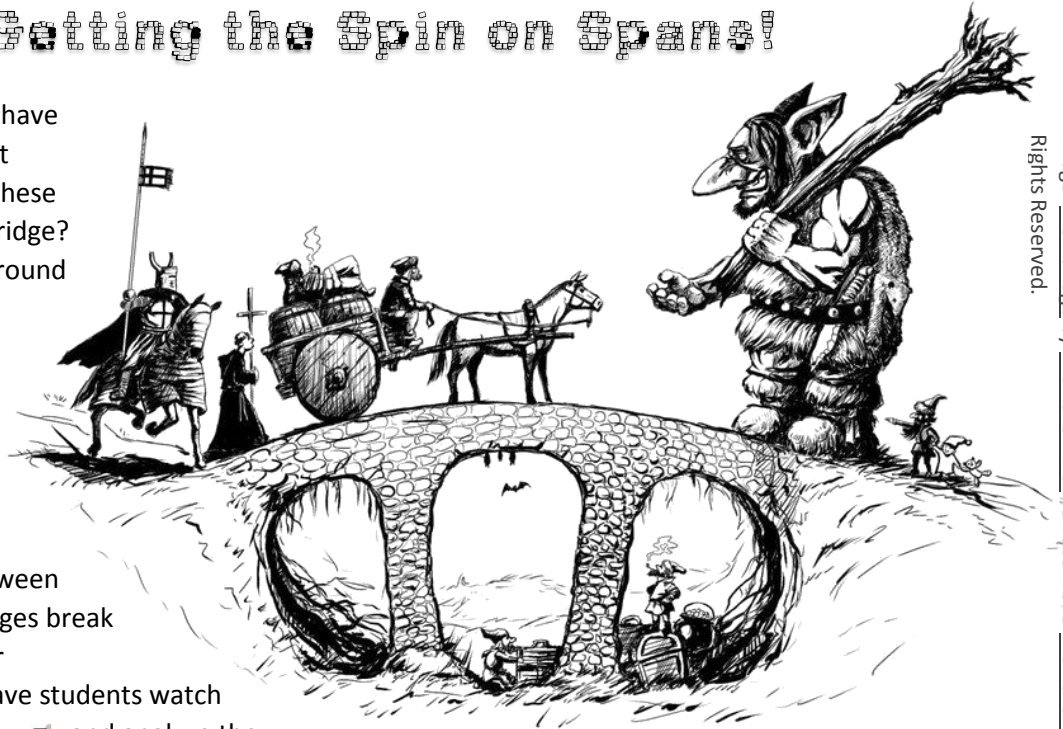

Image: Troll bridge by [Flick-the-Thief](#). ©2009-2015 [Flick-the-Thief](#). All Rights Reserved.

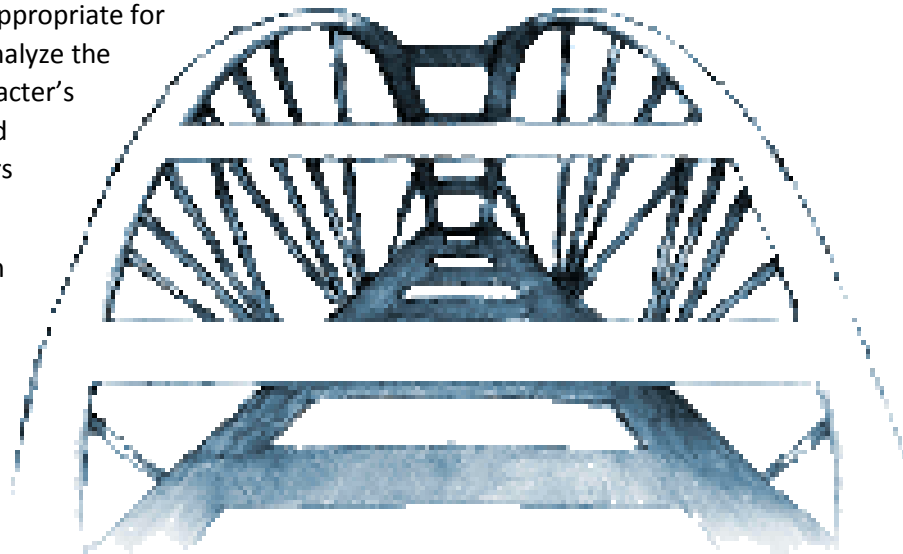

Image via: [Garrett's Bridges](#) by Garrett Boon. Copyright © 2003 - 2015 by [Garrett's Bridges](#). All Rights Reserved.

As far back as we can see in history, human beings have used new technology to solve problems and ease their physical burdens. The distinctiveness of humans as a species is defined by their use of tools, and bridges are technological tools that aim to solve the problem of crossing an obstacle in such a way as to cut down the effort and time needed to do so. The better a bridge is, the less attention the user will need to pay it.

What are the benefits of bridges?

Some of the benefits of bridges are obvious: supplies of food and traded goods can get across an obstacle or through difficult terrain in a shorter time. This means that, in economic terms, the cost of travel and trade falls and the financial benefits of increased social cohesion and sharing resources rise. Other longer-term payoffs from easier travel, which is crucially dependent on good bridges, come as a result of increased opportunities to share ideas – intellectual, political and religious.



A really old bridge at Carrbridge #1e109947

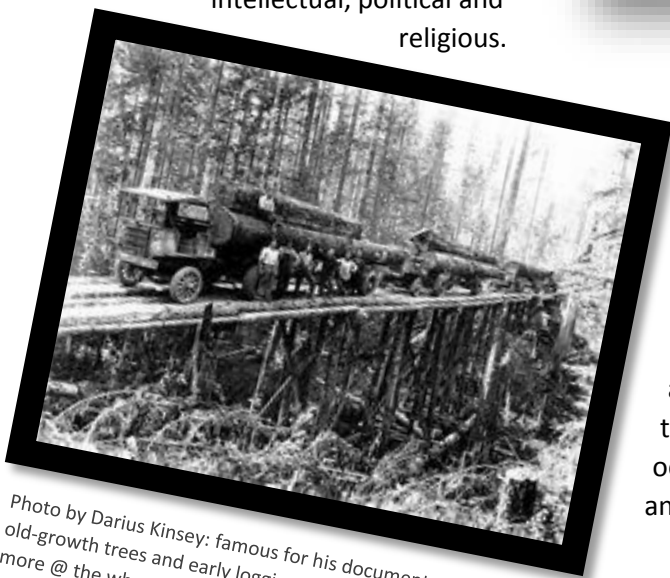

Photo by Darius Kinsey: famous for his documentation of old-growth trees and early logging practices. Read & see more @ the whatcommuseum.org.

Today bridges allow easy travel across major rivers and estuaries, over the new obstacles of motorways and railway lines, and between neighboring islands.

International trade and travel depend on shipping and air routes, but efficient distribution networks depend on bridges.

Bridges started in ancient times, and ever since then architect and engineers improved them to the point they are today – mighty structures that span mountains, lakes and oceans. Bridge history is filled with incredible achievements and new technologies that enabled bridges to become one of

the most important tools of bridging cities, countries and continents. Some of the bridges you cross or see are delicate, ingenious and innovative; others are sturdy, functional and – frankly – may appear a bit, well, dull. Each of them is the end-product of centuries of mental ingenuity coupled with constant technological development, of imagination held in check by the need for safety, reliability and peer approval.

Let's learn their story.

Ancient Bridges

Connection between cities, ports, mines and neighboring civilizations brought the need of creating stable and permanent roads. For this purposes, many ancient civilizations started to leave their mark on history by leveling up uneven terrain, forging their way through wilderness and eventually, bridging rivers and extreme land formations with wood logs and stones.

In the beginning bridges were very simple structures that were built from easily accessible natural resources- wooden logs, stone and dirt. It was what they had! Because of that, they only had the ability to span very close distances, and their structural integrity was not high because mortar was not yet invented and rain slowly but constantly dissolved dirt fillings of the bridge.



Image Via: Mtbikewnc.com. ©1996-2015 CC-BY-SA

These early bridge building efforts finally received massive update in Greece, where builders and mathematicians discovered new ways of molding the weight of bridge material into structures that could remain strong enough to carry incredible weights.

Do as the Romans Do

Some stuff the ancient Romans were good at -- other stuff they weren't. In terms of the abstract sciences and literature, they were always in the shadow of their Greek neighbors. Their poetry never reached the same heights, their philosophies were borrowed, and anyone who's ever used Roman numerals knows how difficult the system was even for even simple arithmetic.

If you wanted someone to explain geometry, you asked a Greek. If you wanted someone to build you a floating [bridge](#), a sewer network or a [weapon](#) that could fire flaming balls of gravel and tar 300 hundred yards (274 meters), you called (or sent a runner to) a Roman. As much as the Greeks gave us, Rome's brilliant architectural, organizational and engineering feats that make them stand out among the ancient peoples. The result is a set of edifices and architectural achievements that stretch from the Limyra Bridge in Turkey to Hadrian's Wall in the United Kingdom.

With so many brilliant examples, many of which are still in excellent condition, it's hard for even modern engineers (and those who visited the Romans at the time) not to have picked up at least a few pointers about how to build structures that last.

So, as you can imagine, with the arrival of Roman Empire, bridge building techniques were revolutionized! The Romans were some of the most important innovators in structural design. Of their contributions, the arch and the bridges they built using an elegant shape stand out as the most creative and enduring.

In this [video segment](#) adapted from

Building Big, series host David Macaulay describes the forces and design

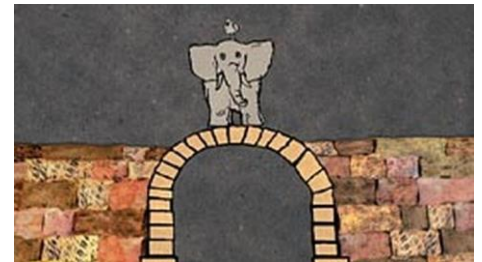

features that give arches their strength.

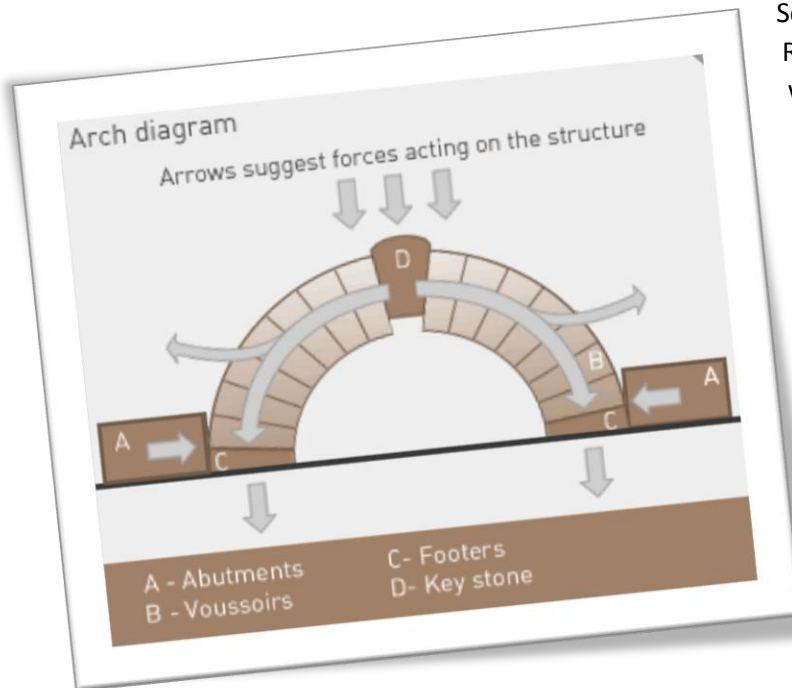

Like almost all of the engineering feats they mastered, the Romans didn't invent the arch (the Sumerians/Mesopotamians did) - but they sure did perfect it. Arches had been around for nearly two thousand years before the Romans got a hold of them. The simplest type of bridge is called a beam bridge. *Roughly half of all bridges in the United States are beam bridges.*

As the name implies, beam bridges are made up of long horizontal supports, called beams, which stretch from one side of a gap to the other. These supports are anchored to solid ground at each end and carry the entire weight of the bridge deck and its loads. Because of this, the distance a beam bridge can span is limited

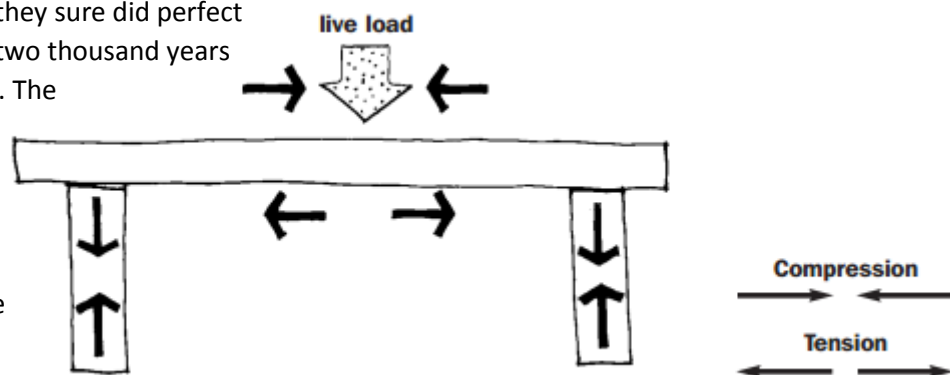

unless it is reinforced underneath by evenly spaced vertical columns, called piers. In a long bridge, however, the piers obstruct the flow of water and traffic along a waterway.

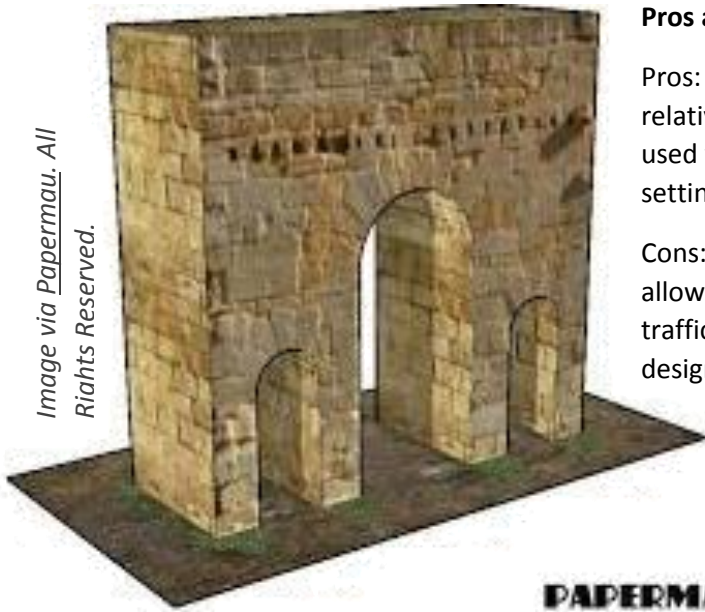

Image via Papermau. All Rights Reserved.

Pros and Cons of Beam Bridges

Pros: Easy to build; inexpensive relative to other bridge types; used widely in urban and rural settings

Cons: Limited span; does not allow large ships or heavy boat traffic to pass underneath; design generally not considered very interesting or eye-catching.

Bridge Brag!
It's the loooooooooooooooooongest bridge in the world, and it's a beam bridge! The Lake Pontchartrain Causeway in Louisiana is approximately 24 miles long, and its twin spans are supported by over 9,000 pilings.

PAPERMAU

While the beam bridge relies on an abundance of material to span long distances, the arch provides a much more elegant solution. It arcs high above the

gap it spans, leaving shipping lanes unobstructed. Despite the arch's delicate appearance, it is remarkably rigid and strong, especially with the extra support commonly placed along its sides.

An arch derives its strength directly from its shape. Downward force from the top of an arch is carried along the curving form all the way to the base. At the same time, the ground pushes up with equal force. As a result, each of the arch's sections are tightly squeezed, or compressed, by adjacent sections, making the structure very rigid. In addition, the curvature of the arch causes the lower sections to push up more steeply than the sections above them push down. This difference in vertical force between upper and lower sections allows an arch bridge to carry loads in excess of its own weight.

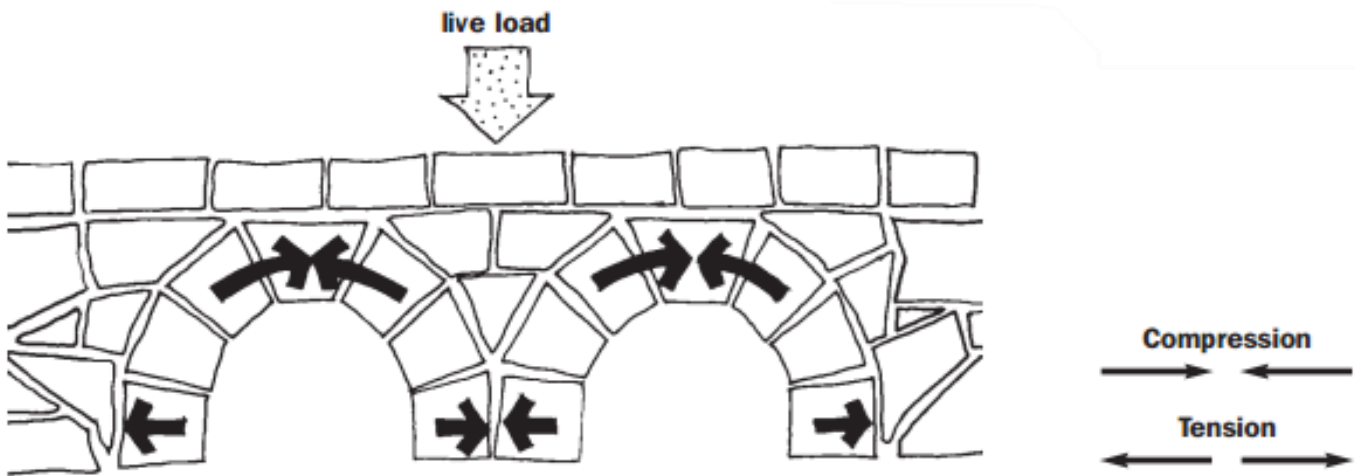

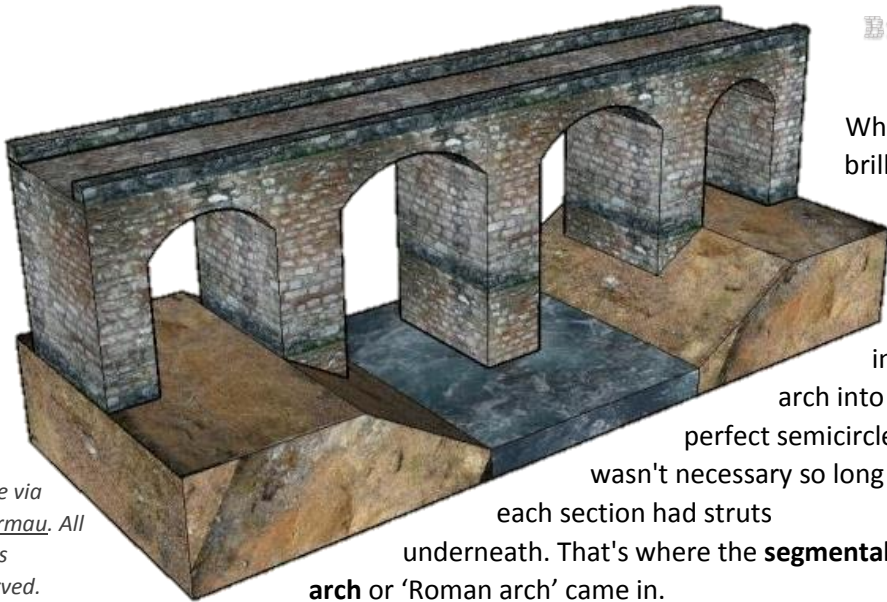

Image via Papermau. All Rights Reserved.

What Roman engineers realized (quite brilliantly, as it turned out) was that arches need not be continuous; that is, they don't have to span a gap in one go. Instead of trying to cross gaps in one great leap, they could be broken up into several, smaller sections. Turning an

arch into a perfect semicircle wasn't necessary so long as each section had struts underneath. That's where the **segmental arch** or 'Roman arch' came in.

Did You Know?

Extending their arch into a tunnel, they invented the barrel vault, with which they successfully roofed such buildings as the Temple of Venus in Rome. Several arches intersecting at a common keystone could be used to form a dome, such as that of the Pantheon in Rome. Two intersecting barrel vaults gave rise to the groin vault, which was used in some of the great Roman public baths.

This new form of arch-building had two distinct advantages. First, because the arches could be repeated rather than having a single stretch across a gap, the potential distance for a bridge span could be increased exponentially. Second, because less material was required, segmental arch bridges were more amenable to the flow of water underneath them. Instead of forcing water through a single small opening, water under segmented [bridges](#) could flow through freely, reducing both danger of [flooding](#) and the amount of wear on the supports.

By using this type of building, load forces of the bridge were conveyed to move along the curve of the arch, meeting with the ground where they were canceled by supports on the end of the arch. The result of this design was an incredibly squeezed material and bridge structure that was very rigid and strong.

Because of that, Romans were able to create bridges that were much lighter than before and were able to hold load that was twice as heavy as the bridge itself. In construction of their numerous aqueducts, Roman architects even managed to create water carrying bridges with multiple arched tiers stacked on top of each other that reached incredible heights!

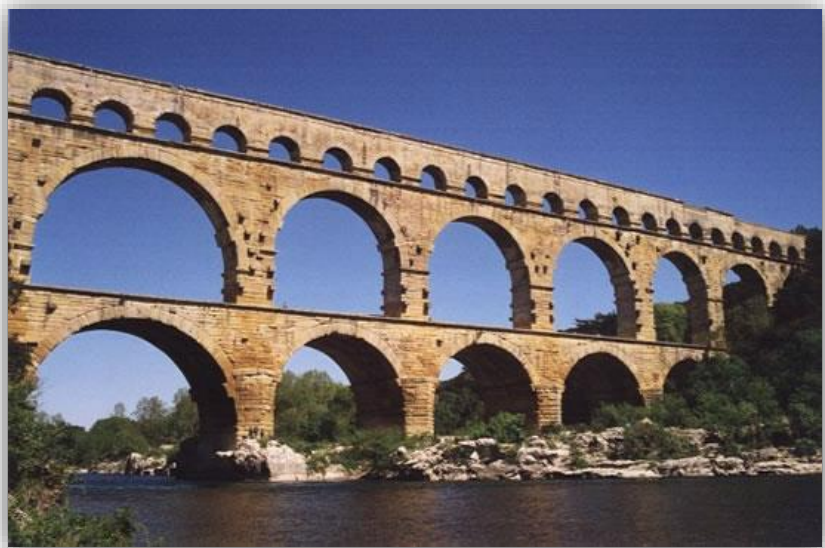

Pont du Gard

Image via: TechnologyStudent.com. V. Ryan © 2006 - 2009 All Rights Reserved.

In the construction of an arch bridge, especially a very large one, the choice of materials is critical. Not all materials are equal in their ability to withstand compression, the force that squeezes a material from opposite sides, and the force that is most important in an arch bridge.

Despite its curved shape, the individual components of an arch bridge undergo very little bending and stretching. They do, however, experience tremendous compressive forces, which are generated by the weight of the load above and the resistant force of the ground below. For good reason, the Romans chose stone for their arch bridges. Very few materials have greater compressive strength than cut stone. Contemporary builders use concrete for arch bridge construction because it can be readily molded into a variety of shapes and it is nearly as strong as, and much less expensive than, stone.

Even then, stone arches were not built entirely from stone. Stone is as expensive today as it was in Roman times. The Romans had a great understanding of material costs and consequently constructed stone bridges and viaducts from a combination of materials. The diagram above shows that accurately cut and shaped stone was used for the external walls. Gravel, sand and rough stone was used to fill all cavities. This filling was cheap to produce and use, compared to cut stone and it could be used by unskilled labor to fill the cavities of structures such as bridges and aqueducts.

By using this new building technique, Romans had the ability to quickly produce cheap, light and very powerful bridges from materials that could be found in the vicinity of the project. Stone in compression has great strength, and the Romans built huge arched bridges and aqueducts in large

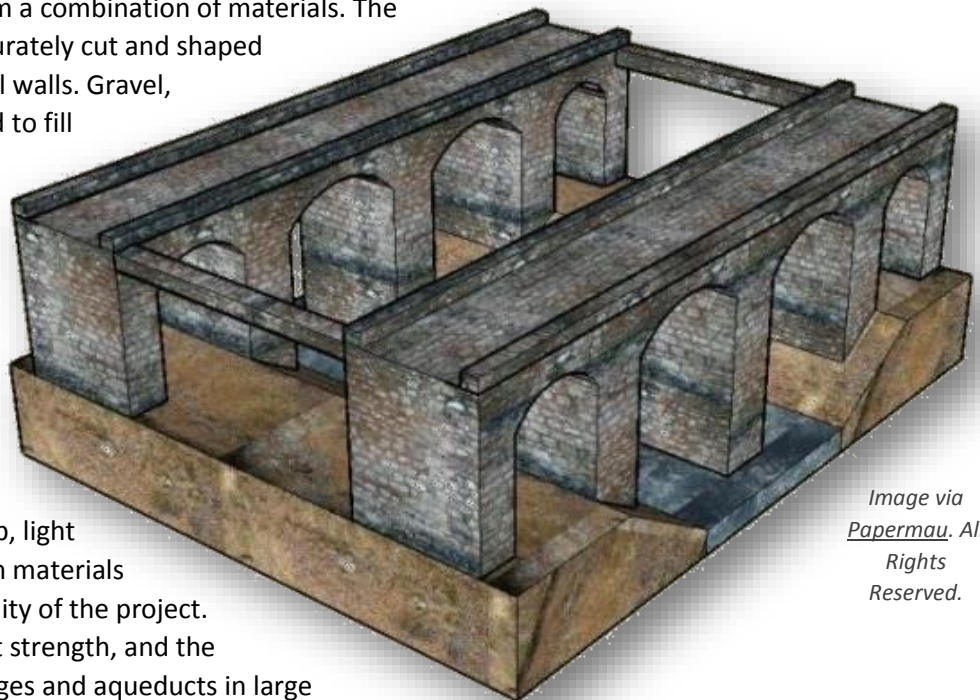
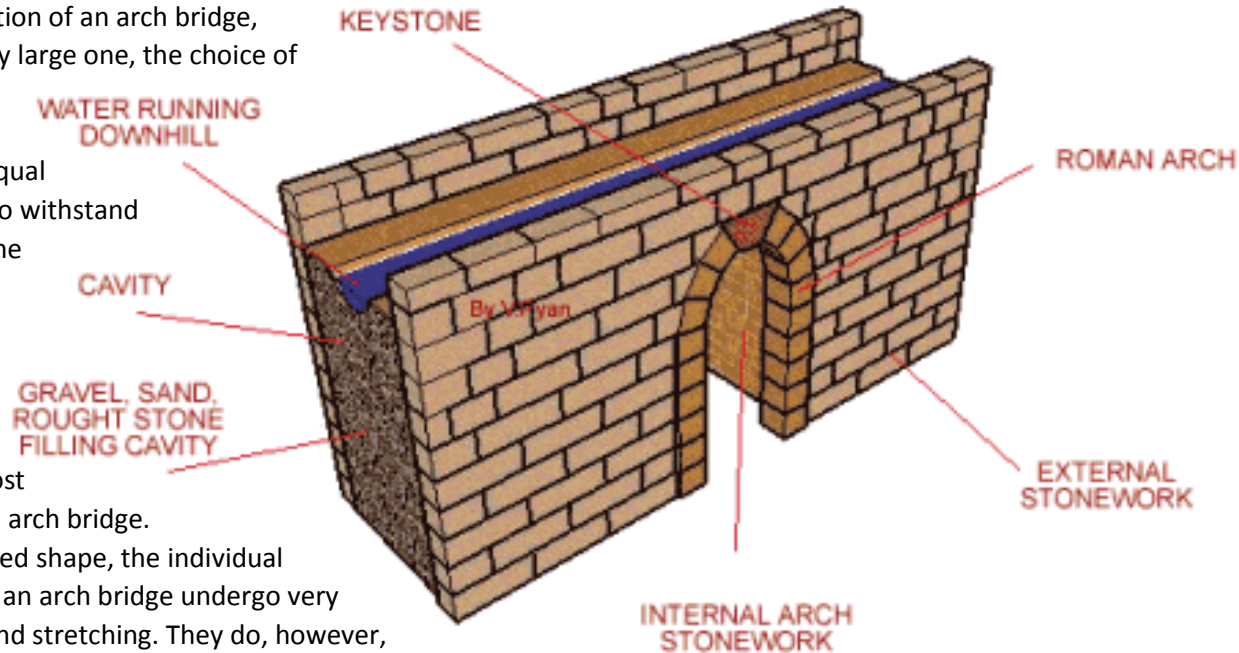

Image via [Papermau](http://Papermau.com). All Rights Reserved.

numbers. The only material that had to be imported from Italy was mortar dust, which was combined with water and inserted into bridge structure.

With such powerful knowledge in their hands, Roman road builders spread across the Europe, Asia and Africa, building over 900 bridges during the life of Roman Republic and Empire.



They did not only build bridges to carry

pedestrians and cargo traffic, but also

incredibly complex aqueducts and viaducts, which carried water and goods from all parts of Europe to Italy. By the end of the third century A.D., Rome was supplied by eleven aqueducts, totaling more than 250 miles in length.

All in all, original Roman bridge architecture reached 26 different modern countries, from Portugal on the west, to Turkey on the east. Testament of the building techniques of Ancient Rome can be witnessed even today, with hundreds and hundreds of their bridges still left standing in all across the world in some cases without any mortar or cement holding the stone blocks together. The integrity of these structures is a direct result of the design of the individual blocks and the way in which the weight of the blocks as well as the loads carried by the structures are distributed within it.

Ponte Fabricio, in Rome, was built in 62 BC. The bridge is almost unchanged, and still serves thousands of Romans today. The Caravan Bridge over the river Meles in Izmir, Turkey was built around 850 BC, which makes it more than 2,860 years old—qualifying as the oldest functioning bridge in the world.

Arch bridges remained the design of choice for heavy traffic bridges for over 2000

years, but bridge engineers were constantly incorporating changing fashions and new materials. And since, the arch has gone through some extraordinary and often beautiful reincarnations. In the last 150

Pros and Cons of Arch Bridges

Pros: Wide range of materials can be used; considered attractive; very strong.

Cons: Relatively expensive; typically designs are limited to certain sites (for example, where the ground can support the large forces at the base of the arch; where the span-to-depth ratio of the arch is proportional; or where an arch is visually appropriate)



years, iron, steel and concrete enabled creation of much more ambitious arch bridges which can now be seen in every country in the world.

The famous Italian artist Leonardo da Vinci once said, “An arch consists of two weaknesses, which, leaning on each other, become a strength.” **Have you seen any new bridges being built that use arches? What about Roman arches? Why do you think this method might not be used as frequently as other bridge designs?**



Roman Arches



Challenge! Build an arch without any glue!

Here is a very simple way to experience the amazing Roman Arch.

Materials:

- Clay
- Ice Cube Tray: The ice cube tray has the perfect angles!

Press clay into the ice tray.

Then release and gently shape the blocks

You need an uneven number of blocks to get a 180 degree arch...7,9, 11. The 'foot' or blocks touching the ground need to be shaped further to create a slight inward slant, so the next block will rest on them.

It takes two people!

Aqueducts are one of the wonders of the Roman Empire. These graceful structures are not only majestic, but are engineering marvels that survive to this day.



Technology Link: In NOVA's "[Construct an Aqueduct](#),"

students are hired as Chief Water Engineer by the Roman Emperor. Your job: to build an aqueduct that will supply the Roman city of Aqueductis with clean water to private homes, public baths and glorious fountains. Succeed, and citizens of Aqueductis will drink clean water and bathe happily. Fail, and there's no telling what your

countrymen will do.

Build a Roman/Sumerian Arch!

Idea & Images via & copyright of [WiseSchool.weebly.com](#). All Rights Reserved.

"Some archeologists believe that the arch was the Sumerians' greatest architectural achievement. Made of bricks, Sumerian arches were inverted U- or V-shaped openings built above doorways. Sumerians built arches by stacking bricks one on top of the other so that the arches projected out from the walls of a building. The bricks rose in steps from the wall and met in the center."

Students are challenged to create an arch using cardboard boxes, pieces of tube and (the optional addition of) masking tape or hot glue (in teacher control). If used, like mortar, the tape or glue will help





Wise School. Image by jmeth@wiseelementary.org

to hold the boxes in place but either way (with or without tape) the strength of the project relies on the design of the arch and team-work.

Optional challenge: Each arch must have a keystone that is different in size and shape from any of the other blocks. If so, you'll need/need to make a few trapezoidal pieces/boxes to use as keystones.

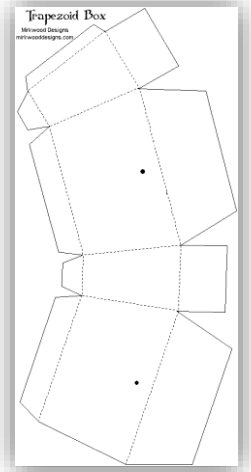

Wise School

Arching Higher

The following cardboard arch or “bridge” project (instructions and images from [Canton Art](#)) is a multi-faceted learning experience, with dramatic and very impressive results. What begins as a fascinating class-room exercise culminates in the construction of a cardboard bridge which spans a corridor, a room, or even a somewhat larger space, ranging in length from 16 feet to 30 feet or more, and rising to a keystone of 8 to 15 feet overhead!

The excitement this project generates among the students is intense, as the “wobbly” arch takes shapes. And when the keystone is dropped into place and the whole construction “stands” all by itself, there is often a burst of applause as the students cheer!

Objective: Build an arch out of cardboard. Each arch must have a minimum of 9 blocks. Each block must be “solid,” in that they must have six solid faces and should not fit inside of one another.

Materials:

- For a smaller arch between 16 to 25 feet in length - approximately 25 sheets of 4' x 5' cardboard,
- 200 lb. card stock B or C flute, bleached on one side, single corrugation (Comes in 5' x 8' sheets, which the supplier can cut in half for you. "Bleached" means that one face is white, which is ideal if you want to paint or decorate the finished arch).
- For a larger arch, 25 feet or more - approximately 50 5 x 8-foot sheets of 200 lb. double-wall cardboard. (This may not be available in "bleached.")
- Four or five rolls of 2-inch wide clear cellophane tape
- Several pairs of scissors
- Long metal straightedges
- Several sharp utility knives (Adults should be entrusted with the task of cutting)
- Pencils
- Paper (including graph-paper for the design phase)
- Compasses
- Rulers
- Tape measure
- Poster-board
- Length of twine or wire

Choose a convenient, wide-open space where you want to construct and install the finished arch. Measure the distance between the walls, and the height of the ceiling. The walls should be free of any obstructions, meeting the floor on each side at a perfect right angle. No heating vents, radiators, or air-conditioning ductwork should be in the way. If the ceiling height is more than half the width of the space, you can build a full semi-circular arch, unless the space between the walls is extremely wide. In this case, the keystone of the arch would be too high for anyone to reach it during the process of assembly. A segmental arch would therefore be preferred. This is also true if the ceiling height is less than half the room width. Instructions for both are provided. Choose the type you are going to build, and refer to the appropriate section of this chapter. Since all of our preliminary work will be done on graph-paper based on a scale, it is recommended that a smaller desk-top model made of poster-board only a foot or two in length is constructed first as a practice session. Once you have measured your large space, transfer the dimensions to a sheet of graph-paper, reduced to an appropriate scale (let's use 1/4-inch = six inches). The preliminary drawing should be a rectangle representing the floor (base line), walls, and ceiling, all drawn to scale. For our exercises we will use a 16-foot span with a 10-foot ceiling, which in the reduced scale comes to 8 inches by 5 inches. Once you learn the formula, you can adjust the arch size to your own specifications. Our arch (in the samples) will be about two feet thick (1 inch scale), and 30 inches (1 ½ inches) deep.

The Semicircular Arch

Steps

1. There are several ways of designing a semicircular arch, from the very simple to the rather complex, the latter offering somewhat more fascinating possibilities. But let's start with a very simple design on poster board. Refer to Figure 13.1, in which the rectangle represents the 8 to 5 inch ratio described above, so you can use the pattern for a small or a large arch. From

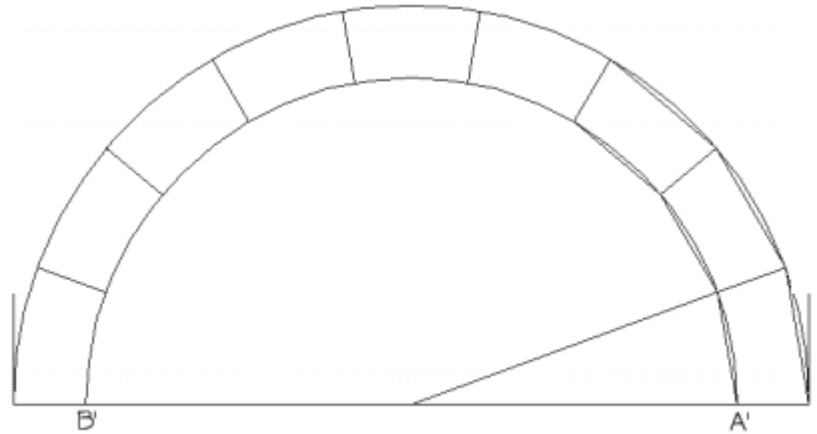
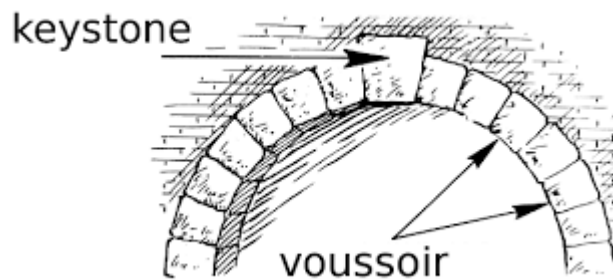

Figure 13.1

2. Now it would be easy to create a perpendicular to center point X, bisecting the circle into two equal sections, and then to continue bisecting the sections into four, or six, or eight equal sections, representing the individual arch "stones" or voussoirs. But we must remind ourselves that arches are made up of an odd number of voussoirs, in order to accommodate a central keystone at the crown. So how do we divide our arch into an odd number of identical voussoirs?



3. Easy. We use a protractor. We know that a semicircle consists of 180 degrees, so we must find an odd number by which 180 degrees can be divided with no inconvenient fractions. Three and 5 will work, but an arch of 3 or 5 voussoirs is hardly much of a challenge! Nine goes into 180 degrees 20 times, meaning that 9 voussoirs, each spanning 20 degrees of arc, would produce an attractive and meaningful arch. Even more so would be an arch of 15 voussoirs, each spanning only 12 degrees of the arc.

4. By placing a protractor on the base line of Figure 13.1 centered on X, mark off the 9 voussoirs 20 degrees apart. You can then square off these voussoirs as we have done with the first few on the right side. Why square them off? Simply because straight cardboard cuts are much easier, faster, and more accurate. Also, cardboard doesn't bend very easily.

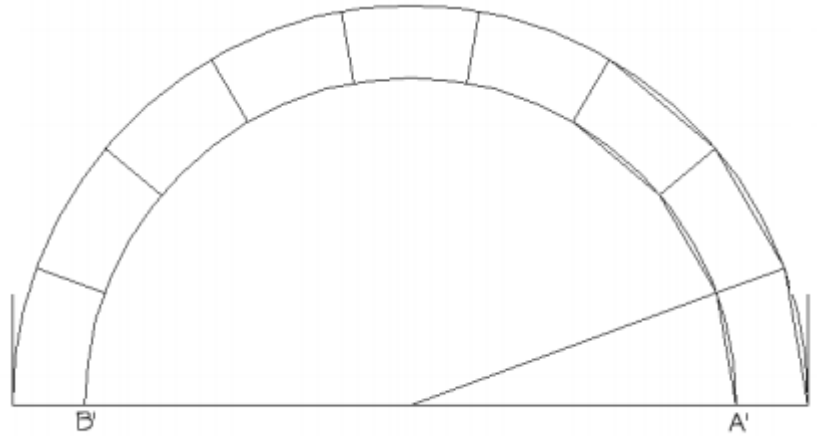

Figure 13.1

- However, poster-board does, and there is no reason why you can't have an attractive curved desk-top arch in poster board if you so desire.
5. Once your design for the arch is complete, you may enlarge it on a copy machine or transfer it to a larger scale for actual construction. All you actually need is one voussoir pattern from your arch pattern (Figure 13.1), separated from all the rest, since all copies will be exactly the same. Once you have done this, you must use this piece—which will actually be a front panel—to design a kind of “box” which will become a three-dimensional voussoir/stone. You must not only add a corresponding back panel (exactly the same as the front), but a top, bottom, and two sides. A sketch is provided in Figure 13.2a, with a fully laid out net (design for the whole box) in Figure 13.2b.
 6. We've given our voussoir a depth of $2\frac{1}{2}$ " , which in large format would be about $2\frac{1}{2}$ '. For the sake of stability, it is always a good idea to make your arch somewhat wider (front to back measurement) than it is thick (top to bottom measurement). Our net has all glue tabs indicated.

Make 9 of these to complete your arch. Assemble the 9 units according to the net given in our figure, and put your arch together.

7. When a team announces that it's ready, time how long the team's arch remains standing without any support or assistance. Take a group picture of each team in front of their arch and of any unique decoration/design features associated with the arch.

Variation: 15 Stones

A 15-unit arch is only slightly more difficult, but the process is exactly the same. In this case, use your protractor to mark off divisions every 12 degrees, as we have shown in Figure 13.4. Each voissior will be somewhat narrower in side view, but should be somewhat deeper front to back.

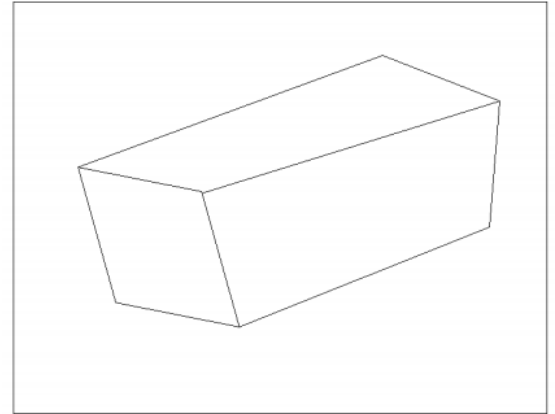

Figure 13.2a

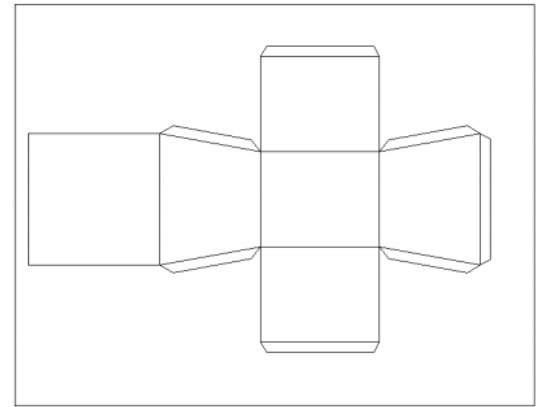

Figure 13.2b

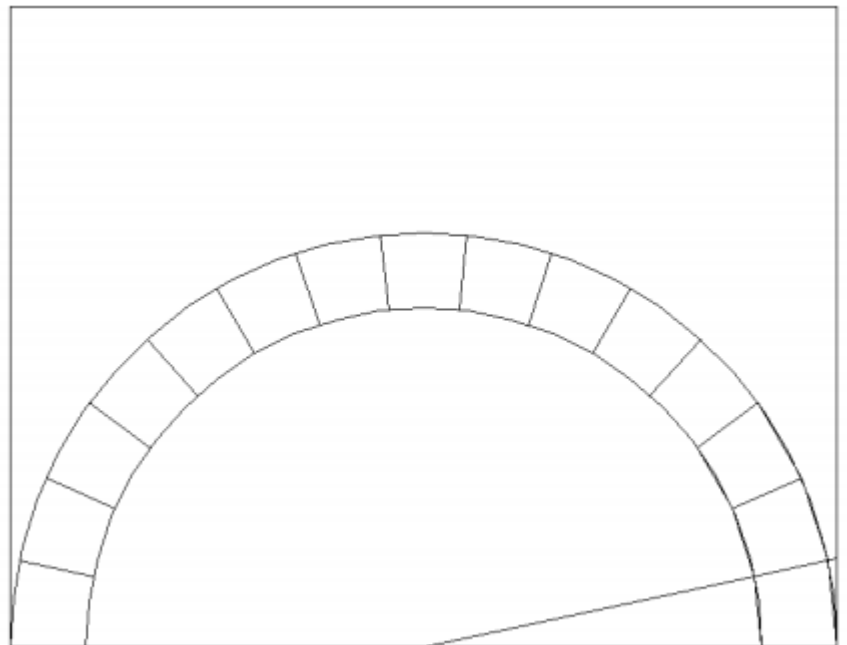

Figure 13.4

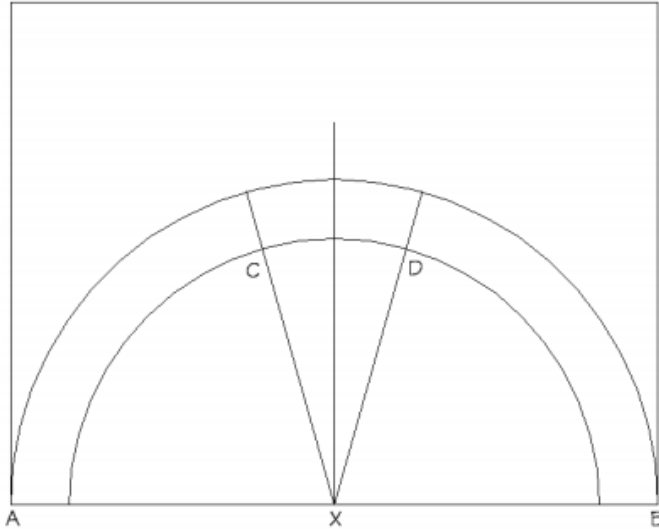

Figure 13.5

Variation: Keystone First!

Another “easy” way to design an arch, this time without the use of a protractor, is to begin by arbitrarily designing the keystone to any practical size you desire. On line AB of Figure 13.5, simply sweep out the two half-circles as before, this time with a perpendicular indicated. Measure off the size of your keystone on each side of the perpendicular on the inner half-circle (C and D in Figure 13.5), and then mark off the edges of the keystone with lines to the center-point of the half-circle, X.

Now, you have merely to bisect the remaining

angles AXC and BXD on each side into two, then 4 sections, and in so doing you will mark off the respective voussoirs of the entire arch (Figure 13.6). Square them off, as we have done to several, by merely converting the arcs of each, top and bottom, into chords. In our illustration, note the difference in size of the keystone to the voussoirs. Then make your boxes!

Tips: A word of advice, fill the two end-blocks with sand to give the arch the necessary support. Here’s an interesting little “trick:” while your arch will hold together all by itself with no glue or tape, you might want to run a strip across the top connecting all the voussoirs—but not at the bottom. Thus, you can “collapse” the arch flat by a little downward pressure. By pulling upward on the keystone, the arch will assume its original shape!

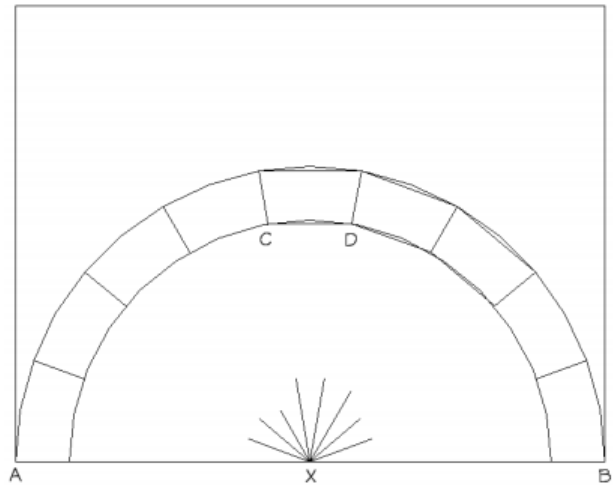
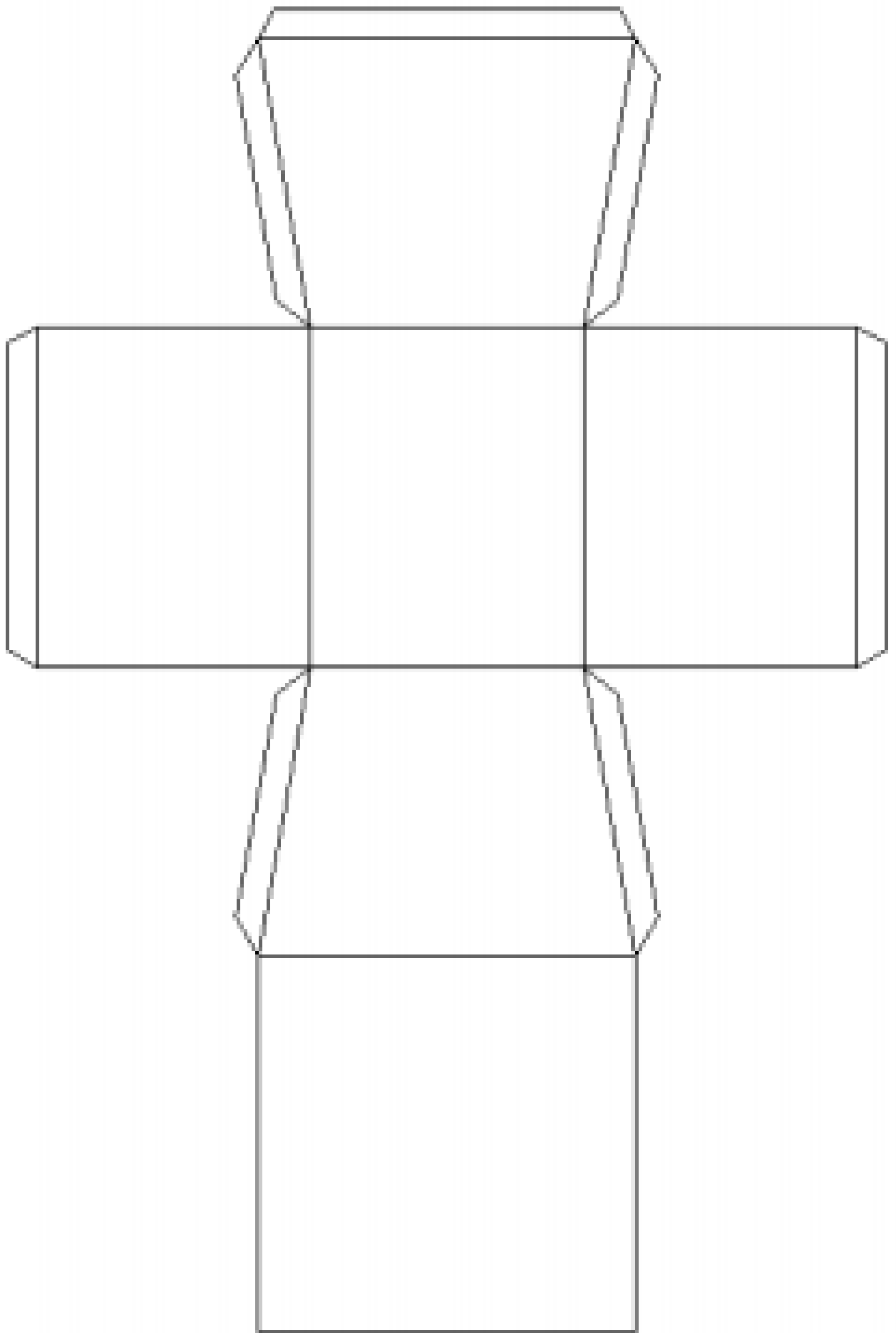

Figure 13.6



Days One & Two K-8 Standard Alignment

K

- 7.T/E.1b Explain how tools are used to extend the senses, make life easier, and solve everyday problems.
- 7.T/E.1a Recognize that both natural materials and human-made tools have specific characteristics that determine their use.

These standards will be met as students study and discuss bridges as technological tools that are used to solve problems, how they are built, and what they are made of. We will learn how both structure and materials as well as the location and other factors determine what can be built, how expensive it is to build, what kinds of loads it can bear, disruption to the environment, etc.

1

- 7.T/E.1a Recognize that both natural materials and human-made tools have specific characteristics that determine their use.
- 7.T/E.1b Explain how tools are used to extend the senses, make life easier, and solve everyday problems.

These standards will be met as students study and discuss bridges as technological tools that are used to solve problems, how they are built, and what they are made of. We will learn how both structure and materials as well as the location and other factors determine what can be built, how expensive it is to build, what kinds of loads it can bear, disruption to the environment, etc.

2

- 7.T/E.1a Recognize that both natural materials and human-made tools have specific characteristics that determine their use.
- 7.T/E.1b Explain how tools are used to extend the senses, make life easier, and solve everyday problems.

These standards will be met as students study and discuss bridges as technological tools that are used to solve problems, how they are built, and what they are made of. We will learn how both structure and materials as well as the location and other factors determine what can be built, how expensive it is to build, what kinds of loads it can bear, disruption to the environment, etc.

3

- 7.T/E.1a Describe how tools, technology, and inventions help to answer questions and solve problems.
- 7.T/E.1b Explain how different inventions and technologies impact people and other living organisms.

These standards will be met as students study and discuss bridges as technological tools that are used to solve problems, how they are built, and what they are made of. We will learn how both structure and

materials as well as the location and other factors determine what can be built, how expensive it is to build, what kinds of loads it can bear, disruption to the environment, etc.



- 7.T/E.1a Describe how tools, technology, and inventions help to answer questions and solve problems.
- 7.T/E.1b Explain how different inventions and technologies impact people and other living organisms.

These standards will be met as students study and discuss bridges as technological tools that are used to solve problems, how they are built, and what they are made of. We will learn how both structure and materials as well as the location and other factors determine what can be built, how expensive it is to build, what kinds of loads it can bear, level of disruption to the environment, etc. We will determine what impact the discovery & modification of the arch had/has in both ancient and modern times.



- 7.T/E.1a Describe how tools, technology, and inventions help to answer questions and solve problems.
- 7.T/E.1b Explain how different inventions and technologies impact people and other living organisms.

These standards will be met as students study and discuss bridges as technological tools that are used to solve problems, how they are built, and what they are made of. We will learn how both structure and materials as well as the location and other factors determine what can be built, how expensive it is to build, what kinds of loads it can bear, level of disruption to the environment, etc. We will determine what impact the discovery & modification of the arch had/has in both ancient and modern times.



- 7.T/E.1 Explore how technology responds to social, political, and economic needs.
- 7.T/E.2 Apply the engineering design process [an ongoing series of events that incorporate design constraints, model building, testing, evaluating, modifying, and retesting] to construct a prototype that meets certain specifications.

These standards will be met as students study and discuss bridges as technological tools that are used to solve problems, how they are built, and what they are made of. We will learn how both structure and materials as well as the location and other factors determine what can be built, how expensive it is to build, what kinds of loads it can bear, level of disruption to the environment, etc. Students will apply what they've learned to successfully construct their own complete arch prototypes (planning, building, testing, rebuilding, adjusting designs, testing, etc.).



- 7.T/E.1 Explore how technology responds to social, political, and economic needs.

- 7.T/E.2 Apply the engineering design process [an ongoing series of events that incorporate design constraints, model building, testing, evaluating, modifying, and retesting] to construct a prototype that meets certain specifications.

These standards will be met as students study and discuss bridges as technological tools that are used to solve problems, how they are built, and what they are made of. We will learn how both structure and materials as well as the location and other factors determine what can be built, how expensive it is to build, what kinds of loads it can bear, level of disruption to the environment, etc. Students will apply what they've learned to successfully construct their own complete arch prototypes (planning, building, testing, rebuilding, adjusting designs, testing, etc.).



- 7.T/E.1 Explore how technology responds to social, political, and economic needs.
- 7.T/E.2 Apply the engineering design process [an ongoing series of events that incorporate design constraints, model building, testing, evaluating, modifying, and retesting] to construct a prototype that meets certain specifications.

These standards will be met as students study and discuss bridges as technological tools that are used to solve problems, how they are built, and what they are made of. We will learn how both structure and materials as well as the location and other factors determine what can be built, how expensive it is to build, what kinds of loads it can bear, level of disruption to the environment, etc. Students will apply what they've learned to successfully construct their own complete arch prototypes (planning, building, testing, rebuilding, adjusting designs, testing, etc.).

Day 5: Cross the Bridge!

a.k.a. Shut the Box!

A game that teaches splitting numbers up to 12 in different ways and gives practice in adding and combining small numbers. (Also can be used to practice multiplication.)

Shut The Box apparently originated in Europe as early as the 12th century, and is also known under such names as "Tric-Trac", "Canoga", "Batten Down The Hatches", "Klackers", "High Rollers", and many more.

Once your kids get hooked on this classic strategy game, you'll want to have dice, paper, and a pen available all the time.

Materials:

- Dice
- Paper or included worksheets (9 or 12 number variations are included)
- Pen/Pencil
- Markers or poker chips

The classic game uses two six-sided dice and a box with hinged tiles numbered 1 to 9. If you don't have a box, you can write the numbers on a piece of paper, then use a coins or poker chips to cover the numbers during the game or simply cross them off.

Each player rolls the dice and crosses off a combination of numbers that match the roll. For example, if you roll a 7 cross off the 7, OR the 5 and the 2, OR the 4, 2, and 1 tiles.

Once a number is crossed off it cannot be used again.

Tip: The higher numbers are harder to get, so you may want to recommend students use combinations first, or let them find this out for themselves after several rounds.

If every number higher than 6 is covered, the player has the choice of rolling one or both dice. The player keeps rolling until they can't match their roll on the remaining numbers.

The total of the numbers left uncrossed are then totaled and the score is recorded. (Variation: The remaining numbers left uncrossed are your score. So, if students couldn't cross off 1, 4, and 9, their score is 149 points, instead of 14. This variation can help reinforce place value.)

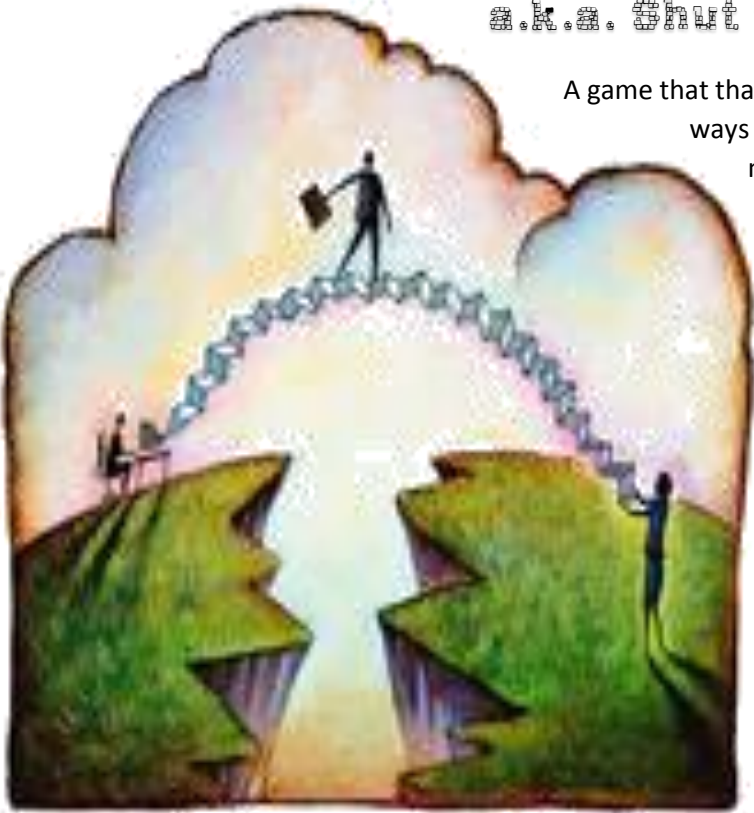



Image via FamilyFun.com

Once the score is recorded, the turn passes to the next player. After each player has played, the game is over, and the low score wins. If you can cross off all of the numbers, you've "Shut the Box" or "Crossed the Bridge."

















































































A game may consist of one round, or many. Typically, the game proceeds thru several rounds, until a player's accumulated score surpasses an arbitrary number, such as 50 or 100. The winner is then the player with **the lowest total score.**

Note: The standard Shut the Box game is played with numbers 1 through 9, but some versions use 1-10 or 1-12. Gameplay is the same with the larger sets of numbers.





















































































































































































Tip: If worried about impatient students: When playing this game, you can give each student a sheet and have students roll at their own pace, while their partner (or partners) rolls too, crossing off numbers on their own sheet/line. That way they don't have to wait for each other. They both (all) play at the same time by rolling the dice and crossing off numbers on their game board. Whoever has the LOWEST score at the end wins.

Bridging the Gap: Weeks 1 & 2

Cross the Gap

									Total Score:
									Total Score:
									Total Score:
									Total Score:
									Total Score:
									Total Score:
									Total Score:
									Total Score:
									Total Score:

Counting

												Total Score:
												Total Score:
												Total Score:
												Total Score:
												Total Score:
												Total Score:
												Total Score:
												Total Score:
												Total Score:
												Total Score:
												Total Score:
												Total Score:
												Total Score:
												Total Score:
												Total Score:

Day Three K-5 Math Skills

The following are selected from the comprehensive list of the math skills students learn in each grade. Remember, these skills build on each other. They are assuming that students have mastered all the ones in the previous grades.

The skills are organized into categories: As you read (and complete) the activities in the plan, keep in mind the specific skills your students need to practice and master in the different grade levels you work with. Use their needs to guide your approach in how you'll modify and present the activities and what specific tasks you will have the students do.



Numbers and counting up to 10

- C.1 Count to 10
- C.2 **Count dots - 0 to 10**
- C.3 Represent numbers - up to 10
- C.4 Count by typing - up to 10
- C.6 Count up - with numbers
- C.7 Count up and down - with pictures
- C.8 Count up and down - with numbers
- C.9 Tally marks - up to 10
- C.11 Before, after, and between - up to 10
- C.12 Count forward - up to 10
- C.13 Count forward and backward - up to 10
- C.14 Names of numbers - up to 10

Comparing

- G.1 Fewer, equal, and more
- G.2 Fewer and more - comparing groups

Adding

- I.6 Addition with pictures - sums up to 10
- I.7 Add two numbers - sums up to 10
- I.8 Addition sentences - sums up to 10
- I.9 Ways to make a number - sums up to 10

Probability

- P.1 More or less likely



Counting and number patterns

- A.1 Counting review - 0 to 10
- A.2 Counting review - up to 20

Addition

- B.1 Addition with pictures or dots- sums to 10
- B.2 Addition sentences - sums to 10
- B.3 Addition word problems - sums to 10
- B.5 Ways to make a number using addition
- B.6 Ways to make a number - addition sentences

- B.8 Adding doubles
- B.9 Addition facts - sums to 10
- B.10 Addition facts - sums to 18

Mixed operations

- F.1 Addition and subtraction - ways to make a number

Comparing

- G.2 Comparing numbers up to 10
- G.3 Comparing numbers up to 100

Probability and statistics

- P.1 More, less, and equally likely
- P.2 Certain, probable, unlikely, and impossible



Addition - one digit

- E.1 Review - add one-digit numbers - sums to 10
- E.2 Review - ways to make a number - sums to 10
- E.3 Review - writing addition sentences - sums to 10
- E.4 Add one-digit numbers
- E.5 Addition with pictures - sums to 20
- E.13 Add three or more one-digit numbers

Addition - two digits

- G.1 Add multiples of 10
- G.2 Add a two-digit and a one-digit number - without regrouping
- G.3 Add a two-digit and a one-digit number - with regrouping
- G.4 Add two two-digit numbers - without regrouping
- G.5 Add two two-digit numbers - with regrouping

Mixed operations

- L.1 Add and subtract numbers up to 20
- L.2 Addition and subtraction - ways to make a number - up to 20
- L.6 Add and subtract numbers up to 100
- L.7 Addition and subtraction - ways to make a number - up to 100

Logical reasoning

- O.1 Guess the number

Probability and statistics

- V.1 More, less, and equally likely
- V.2 Certain, probable, unlikely, and impossible



Place values

- B.2 Place value names
- B.3 Value of a digit
- B.4 Identify the digit with a particular place value

Numbers and comparing

- A.9 Which number is greatest/least?
- A.10 Comparing numbers

- A.11 Comparing - with addition and subtraction

•

Addition

- C.1 Add two numbers up to three digits
- C.6 Add three or more numbers up to three digits each
- J.4 Solve using properties of addition

Logical reasoning

- M.1 Guess the number
- M.2 Largest/smallest number possible
- M.3 Find the order

Probability and statistics

- U.1 Certain, probable, unlikely, and impossible
- U.4 Combinations (as in how many combinations of things can be made)



Number sense

- A.1 Place values

Addition

- B.1 Add numbers up to millions
- B.3 Addition: fill in the missing digits
- B.4 Properties of addition
- B.5 Add 3 or more numbers up to millions
- B.7 Choose numbers with a particular sum

Mixed operations

- F.7 Choose numbers with a particular sum, difference, product, or quotient
- F.8 Mentally add and subtract numbers, ex. those ending in zeroes

Probability and statistics

- V.1 Calculate probability or chances
- V.2 Make predictions
- V.5 Combinations (as in how many combinations can be made?)



Place values and number sense

- A.1 Place values

Addition and subtraction

- D.1 Add and subtract whole numbers [up to billions]
- D.7 Choose numbers with a particular sum or difference
- D.8 Properties of addition
- D.10 Estimate sums and differences of whole numbers

Problem solving

- J.3 Guess-and-check problems

Probability and statistics

- Y.4 Calculate probability/chances
- Y.5 Make predictions
- Y.6 Combinations



Whole numbers

- A.1 Place values in whole numbers
- A.2 Word names for numbers

Add and subtract integers

- I.1 Review - add and subtract whole numbers
- I.3 Properties of addition

Probability

- BB.1 Combinations
- BB.2 Probability of one event
- BB.3 Make predictions



Operations with integers

- E.1 Integer addition and subtraction rules
- E.2 Add and subtract integers using counters
- E.3 Add and subtract integers

Problem solving and estimation

- M.1 Estimate to solve problems
- M.2 Multi-step problems
- M.3 Guess-and-check problems

Properties

- Properties of addition

Probability

- Z.1 Probability of simple events
- Z.2 Probability of opposite, mutually exclusive, and overlapping events
- Z.4 Make predictions



Operations with integers

- C.1 Integer addition and subtraction rules
- C.2 Add and subtract integers using counters
- C.3 Add and subtract integers
- C.4 Add and subtract three or more integers

Problem solving

- M.1 Multi-step problems
- M.2 Guess-and-check problems

Properties

- AA.1 Properties of addition

Probability

- BB.1 Probability of simple events
- BB.2 Probability of opposite, mutually exclusive, and overlapping events
- BB.4 Make predictions

Days 4 & 5: Roman Empire's Falling Down, Falling Down...

After the fall of the Roman empire, bridge building techniques in Europe and Asia stagnated until the 18th century (if we think Euro-centrally and ignore introduction of Rope suspension bridges that were brought back to Europe from Central and South America) when new age of science and engineering swept across the world. Architects of that time started using new construction material – cast iron! Iron enabled creation of new bridge designs such as truss systems. Sadly, wrought iron did not have tensile strength to support heavy structures, which was fixed with the advent of steel and the ideas of famous French architect and engineer Gustave Eiffel.

Modern bridges are usually made with the combination of concrete, irons and cables, and can be built from very small sizes to incredible lengths that span entire mountains, rough landscapes, lakes and seas.

Let's Not Ignore the Rest of the World

Around the late BC and onwards, European explorers were fascinated to discover new parts of the world. Due to Europe's lack of knowledge back then, and their lack of geographical skills, they were unaware of the technological advancements that places other than Europe were making. Although the UK and France, for example, had booming empires and economies, tribes and towns in other continents were making unknown breakthroughs, and had been for a long time.

Even in the art of bridging gaps.

Balanced on a Blade...of Grass?

Marvels like today's Golden Gate Bridge or the Brooklyn Bridge owe their existence to a technological breakthrough: the development of high-tension steel from iron. But what do people do when the only material they have in abundance is grass? They use it. That's what the Inca people of what is now South America have done for hundreds of years.



Would you cross a raging river 18 m (59 ft) below, knowing the only thing that supported you was a bunch of grass? Using nothing but simple blades of grass, Andean villagers built a suspension bridge strong enough to support the weight of several people.

Conquistadors from Spain came, they saw, and they were astonished. They had never seen anything in Europe like the bridges of Peru. Chroniclers wrote that the Spanish soldiers stood in awe and fear before the spans of braided fiber cables suspended across deep gorges in the Andes, narrow walkways sagging and swaying and looking so frail.



Images & information via By [Atlas Obscura](#) on [Slate](#). All Rights Reserved. More [photos of the Keshwa Chaca](#) can be seen on [Atlas Obscura](#).

The Andean spans were far longer than anything that they'd seen in 16th-century Spain, where the longest bridge stretched only 95 feet. The Incas' building materials must have seemed almost miraculous. European bridge-building techniques derived from stone-based Roman technology, a far cry from these floating webs of grass. No wonder some of the bravest conquistadors were said to have inched across on hands and knees.

The Incas didn't invent the wheel, never figured out the arch, and never discovered iron. But they were masters of fiber. The ancient Inca were a textile society and thus skilled in working with natural fibers



including alpaca and cotton. They built ships out of fiber. (You can still find reed boats sailing on Lake Titicaca.) They made armor out of fiber, which was stronger, pound for pound, than the steel worn by the conquistadors. Their greatest weapon, the sling, was woven from fibers, and it was powerful enough to split a Spanish sword. They even communicated in fiber, developing a language of knotted strings known as *quipu*, which has yet to be decoded. And so when it came to solving a problem

like how to get people and goods across the steep gorges of the Andes, it was only natural that the Incas would look to fiber for a solution.

Still, it might surprise people today that their solution to crossing the canyons and gorges of their mountainous empire featured another fibrous material: grass. When you consider how they built a simple suspension bridge, you'll realize that not only was this a practical solution, it was also a safe one.

Five centuries ago, the Andes were strung with suspension bridges. By some estimates, there were as many as 200 of them, braided from nothing more than twisted mountain grass and other vegetation, with cables that were sometimes as thick as a human torso. At least 300 years before Europe saw its first suspension bridge, the Incas were spanning longer distances and deeper gorges than anything that the best European engineers, working with stone, were capable of.



Images & information via By [Atlas Obscura](#) on [Slate](#). All Rights Reserved. More [photos of the Keshwa Chaca](#) can be seen on [Atlas Obscura](#).

Ultimately, the bridges—and indeed, the whole meticulously maintained Inca roadway system—facilitated the Spanish conquest, especially when it became clear that the bridges were strong enough to bear the weight of horses and even cannons.

Despite the Inca bridges' utility, the Spanish were determined to introduce more familiar technology to the Andes landscape. (Perhaps they weren't keen to swap out each woven overpass every year or



two, as the Inca carefully did.) In the late 1500s, the foreigners embarked on an effort to replace the grass suspension bridge over Peru's Apurimac River with a European-style stone compression bridge, which depended on a masonry arc. But "to construct a timber arch of sufficient strength to support the weight of stone over the rushing river was simply beyond the capacity of colonial Peru," writes John Ochsendorf, an MIT professor and MacArthur fellow who researches the engineering accomplishments of ancient civilizations, "The bridge construction was abandoned after great loss of life and money."

Grass Bridge: In this [video segment](#) adapted from NOVA, watch residents of the Peruvian Andes as they build a traditional and functioning grass bridge—the likes of which enabled the ancient Inca people to flourish for several hundred years. And watch [The Last Incan Grass Bridge: Keshwa Chaca](#) from Atlas Obscura

Until recently, little more was known about traditional grass suspension bridges than that several hundred or more of these natural-fiber structures once spanned formidable obstacles—the canyons and rivers of the Andes Mountains. These bridges enabled the Inca Empire, the largest empire of the pre-Industrial world, to flourish and to expand into new territory. When the Spanish conquistadors arrived in the 16th century, they marveled at this technological achievement.

The bridges, built from nothing more than braided grass and wood fibers, spanned distances longer than those of any bridges in Europe at the time.

Although these structures were made from natural fibers, modern researchers have come to realize (what native people have always known) that these bridges were much more than just ropes thrown across canyons. Rather, they were engineered—deliberately designed and built—in much the same way





that modern suspension bridges are. For the foundations, the Inca created pairs of stone abutments on either side of a crossing. These served as the anchors between which a roadway was suspended. These served as the anchors between which a roadway was suspended. [Rope bridges rely on their connections at each end. They are *always* under tension so attachments need special consideration to take into account both weight (vertical load) and the tension of the bridge (acting horizontally).]

Today, there is just one Incan grass bridge left, the *keshwa chaca*, and just

one last Incan bridge-keeper. His name is Victoriano Arisapana. In the desolate, 2-mile-high Andean altiplano, little else grows besides *ichu*, a tall needly grass that covers the mountainsides, feeds the llamas, and is the raw material from which the *keshwa chaca* is constructed. Unlike a modern suspension bridge, where the roadway hangs from suspended cables, the roadways of Incan bridges are the cables themselves. The *keshwa chaca* consists of just four parallel ropes with a mat of small twigs laid across, anchored at both ends by a platform of larger rocks. Two other thick cables act as arm rails and are connected to the roadway with a cobweb of smaller cord.

Five centuries ago, at the height of the Incan empire, there would have been dozens, perhaps hundreds, of men like Arisapana throughout the Andes; they carried the title of *chacacamayoc*, or bridge-keeper. Each was responsible not only for maintaining and administering a bridge, but also for collecting tolls and helping frightened travelers across.

As depicted in the [video segment](#), which features the only Inca bridge crossing still in use (According to locals, it has been there for at least 500 years.), each of the four or more thick main cables that made up the roadway was actually a



braid of three thinner cords. In turn, these thinner cords were each made up of two-dozen two-ply strands of grass that nearby villagers had twisted together by hand.

Did Chuño?

Chuño or *chuño* is a freeze-dried potato product traditionally made by Quechua and Aymara communities of Bolivia and Peru, and is known in various countries of South America, including Argentina, Bolivia, Chile and Peru. It is a five-day process, obtained by exposing a frost-resistant variety of potatoes to the very low night temperatures of the Andean Altiplano, freezing them, and subsequently exposing them to the intense sunlight of the day (this being the traditional process). The word comes from Quechua *ch'uñu*, meaning 'frozen potato' ('wrinkled' in the dialects of the Junín Region). The existence of *chuño* dates back to before the time of the Inca Empire in the 13th century

The roadway was covered with a mat made of branches. Two additional cables served as protective handrails, which were secured to the roadway by vertical ties.

Grass bridges tend to sag in the middle under their own weight and to sway in high winds, but despite their flimsy appearance, recent tests show that their design is structurally sound. In fact, they meet the benchmark for today's safety standard, which is to build a bridge three to four times stronger than the loads it will have to support.

The first conquistadors to encounter grass bridges pronounced them "the work of the devil" and trembled at the thought of crossing. Ultimately, the Spanish discovered that the largest bridges were strong enough to carry not only horses but also cannons, as well as an army marching two-by-two. Indeed, modern load-testing by John Ochsendorf, an MIT professor and MacArthur fellow who researches the engineering accomplishments of ancient civilizations, has found that a length of *keshwa chaca* cable can sustain 4,000 pounds of tension. Ochsendorf estimates that in peak condition, the small bridge could support the weight of 56 people spread out evenly across its length.

Exposed to the weather, the grass ropes of the *Q'eswachaka* or *keshwa chaca* wouldn't hold up for more than a couple of years. Unlike the Golden Gate or George Washington bridges, which are almost constantly being repaired, an Incan bridge can't be patched up or have parts swapped out. It can only be replaced wholesale. The largest Incan bridges were maintained by the state and supported by a system of compulsory public service that demanded several weeks' labor by every grown male each year. In the case of smaller communal bridges, like the *keshwa chaca*, the work of regularly rebuilding the bridge fell to local communities. To this day,

the four surrounding villages convene in the valley each June for a three-day festival to cut down the previous year's *keshwa chaca* and replace it with cables twisted from fresh *ichu*. Each household is responsible for bringing 90 feet of braided cord to the ceremony. The entire process happens under the orchestration of the *chacacamayoc*, Arisapana. It takes about 10 miles of cord to make the entire bridge.

When the four Quechua communities convene, they first ask the Pachamama for permission and then collect the *q'oya* ropes braided by women and young girls. The *chakarauwaq* (engineers) tie the ropes, let the old bridge fall, and begin weaving. Once finished, they give thanks to Apu *Q'eswachaka* (mountain spirits).

At each stage of the building process, the *chakarauwaq* make offerings of coca leaves, potatoes, and corn to the *apus* (spirits of the mountains). When the bridge is finished, the community gives thanks,

celebrating with music, *chuñu phasi* (freeze-dried potatoes), and *chicha* (corn beverage, also related to *horchata*).

In 1968, the government built a steel truss bridge just a few hundred yards upstream from the *keshwa chaca*. Though most locals now use it rather than the grass bridge to cross the gorge, the tradition of rebuilding the *keshwa chaca* each year still continues. Divorced from practical necessity, its annual renewal has become an impassioned, highly ritualized act of cultural preservation.

Watch the fascinating video ***BUILDING THE Q'ESWACHAKA*** from the Smithsonian [here](#), Produced by Noonday Films for the National Museum of the American Indian exhibition, *The Great Inka Road: Engineering an Empire*



Then watch the short film *The Q'eswachaka from Cusco to D.C.* ([here](#)) where the builders are interviewed.

Today, the nearby metal truss bridge shows signs of wear. Its orange paint has grown rusty. Its wood planks are rickety. One of the metal barriers is badly warped from a vehicle collision. It was built as a permanent replacement for an inherently impermanent structure. But nothing is truly permanent. All bridges someday collapse. And it's not impossible to imagine that it may yet be outlived by its more fragile neighbor downstream, whose very ephemerality seems to be the source of its staying power.

Inca bridges, like Roman arch bridges, are examples of very successful bridge designs that have survived for centuries and continue to carry traffic today. Each of these bridge types was made using materials readily available to the people building them.



In modern bridges, materials used instead of (fiber) rope include wire rope, chain, and special-purpose articulated steel beams.

- Did you ever think that grass could be strong enough for building a bridge? How did the Inca work with grass to make it strong enough?
- Why do you think the Inca chose grass as the material for building their bridge?
- What constraints did the Inca have in solving their design problem? (limited materials, 150-foot width to cross)

- Compare suspension bridges that you have crossed to the one made by the Inca. How are they similar? How are they different? What material is the bridge that you crossed made of and why do you think the engineers chose this material? How are engineers influenced in their bridge designs by what will have to cross the bridge?

Living Bridges

In the depths of northeastern India, in one of the wettest places on earth, bridges aren't built — they're grown. Around Cherrapunji in northeast India there are living root bridges, a form of tree shaping, which are simple suspension bridges made of living tree roots of some suitable species such as *Ficus elastica* growing alongside the gap to be bridged, by gradually training some of its roots to grow across the gap until they take root on the other side. There are examples with a span of over 100 feet (30 meters). They are naturally self-renewing and self-strengthening as the component roots grow thicker and some are thought to be more than 500 years old.



The root bridges, some of which are over a hundred feet long, take ten to fifteen years to become fully functional, but they're extraordinarily strong — strong enough that some of them can support the weight of 50 or more people at a time. In fact, because they are alive and still growing, the bridges actually gain strength over time — and some of the ancient root bridges used daily by the people of the villages around Cherrapunji may be well over 500 years old.

One special root bridge, believed to be the only one of its kind in the world, is actually two bridges stacked one over the other and has come to be known as the "Umshiang Double-Decker Root Bridge."

Local dedication to the bridges has kept them from being destroyed in favor of steel ones. What's more, a new root bridge at the double-decker site is currently being grown and should be ready for use within a decade.

In the Iya Valley of Japan, bridges have been constructed using wisteria vines — a particularly aggressive and tough vine that climbs around any host.

To build such a bridge, these vines are planted on opposite sides of a river and woven together when they grow long enough to span the gap. Then planking was woven into them at 8 to 12

inches apart. The bridge had no sides and a Japanese historical source relates that the original vine bridge was so unstable, that when those who were not used to it attempted to cross, the bridge would start to sway and bounce wildly causing the poor soul to freeze in place, unable to go any farther. No doubt this suited the reclusive residents of Iya Valley just fine.



"Terrified on the Vine Bridge"
Photo by [theizumis/Flickr](#)

No one is sure exactly who first created the vine bridges that reach across the Iya River (there were at least 13 at one point), although a couple of popular theories exist, both steeped in folklore. One tale says that the bridges were created by spiritual figure Kōbō-Daishi, the founder of Shingon Buddhism. Assumedly he came to the impromptu solution while traveling in the area and the idea caught on well enough to become a tradition. The other school of thought is that the bridges were originally the work of the legendary Heike refugees who would have built the bridges while fleeing from the Genji Clan, in search of a safe place to settle down. The idea was that the bridges could be easily cut down, turning the river valley into a naturally impassible barrier to their enemies.

Local artisans have continued to keep the bridges alive, and while the number of bridges has dwindled to three, they are no less amazing. The largest and most accessible of the spans is the Iya Kazurabashi Bridge which reaches almost 150 feet across the valley at a height of almost 50 feet above

the water. This more popular of the vine bridges is in West Iya, quite close to the main village, but the most beautiful vine bridges are a pair found in the east of the valley, known as the husband and wife bridges. Though stories range as to their origins, some believe they were built in the 1100s.

While some (though apparently not all) of the bridges have been reinforced with wire and side rails, and each bridge is rebuilt every three years, they are still harrowing to cross. 147 feet long, with planks set seven inches apart and a drop of four and a half stories to the water, and a swaying



Picture from the 1880s one of the original bridges. Photo by Okinawa Soba @ Atlas Obscura. © 2015 Atlas Obscura. All rights reserved.

sensation accompanying every footstep, they are not for those with a fear of heights. About a two-hour drive from Tokushima City, the bridges can still be crossed for 500 yen.

Option: More to Explore! Look at a few interesting and challenging bridges from around the world with [The 68 Most Bizarre & Perilous Bridges](#) according to WebUrbanist.com.

Hang In There!

Then, during the following activity (from [NOVA](#) Images & Instructions © WGBH Educational Foundation. All rights reserved.) we're going to try building our own cables using strips of newspaper (grass, roots, and vines might take more time than we have)!

Materials for Each Group

- newspaper
- four paper clips
- paper cup
- scissors
- tape
- stapler

- weights (such as washers, coins, books)
- various pieces of string, yarn, thread, twine, or rope
- hole puncher
- two chairs
- sheet of paper

1. Organize students into small groups and distribute a set of materials to each group.
2. Encourage students to look at the weave in samples of thread, string, yarn, and rope as they investigate ways to increase the weight-bearing strength of newspaper strips.
3. Provide students with weights or washers to test simple cables. As the amount of weight the cables can sustain increases, students can suspend heavier objects, such as books. When twisting or braiding strips, students might want to staple or tape the ends together. Ask students how the staples or tape might affect the strength of the newspaper and have them think of ways to combine newspaper strips without these materials.



Student Procedure:

1. Cut the newspaper into 5 cm (2 in.) wide strips.
2. Build a load tester to test how much weight the newspaper strips can hold.
 - a. Unfold four paper clips into “S” shapes.
 - b. Punch three holes around the sides of the paper cup. Make sure the holes are spaced evenly just below the top of the cup.
 - c. Slip a paper clip through each hole in the cup.
 - d. Place a fourth paper clip through the other paper clips to make a hanger.



load tester

3. Place two chairs so that they are about 60 cm (2 ft) apart. Tape an end of a newspaper strip securely to the top of each chair so that it sags slightly in the middle. Hook the load tester to the center of the strip, and measure how much weight the newspaper strip can hold until it breaks

4. On a separate sheet of paper (or use the included form) create a two-column chart to record your results. Draw and describe the newspaper strip in the first column; record the weight the strip can hold in the second column.
5. Now invent ways to increase the strength of the newspaper strip. Try twisting two strips together as the Inca did. Think of other methods to create other kinds of cables. For each method you invent, describe it in your chart and record the weight it holds. (As the weight increases, you can try hanging heavier objects from the cable.)

Questions for Discussion

- 1 Which cable design was able to support the most weight? Why?
- 2 Which design could support the least? Why?

Challenge! Now, challenge students to create a strong cable using a limited amount of newspaper. Give each team the same amount of newspaper (such as the front section) and have them create a cable that spans 2 m (6.5 ft) and supports the most weight. Ask each team to describe the method it used and why. Which method(s) sustained the most weight and used the materials most efficiently? Discuss how sometimes there is no one best design and how many different designs can meet the challenge.

Activity Answer Guide: Students' cable designs will vary. They will find that multiple strips of newspaper are able to support more weight than a single strip. They should also notice that many different methods support the same amount of weight. Students can evaluate methods using criteria such as the most efficient use of material, the most easily constructed method, or the method that supports the greatest amount of weight.

Ask students if they've ever crossed a suspension bridge. There are a number of suspension bridges in the United States, including the George Washington Bridge in New York City. This bridge spans 1.1 km (3,600 ft) and is supported by four main cables. Each cable is 1.6 km (1 mi) long and contains 26,000 strands of steel. If all of the strands that make up the cables were laid end to end, they would circle the earth four times.

Draw & Describe your Newspaper Strip	Weight the Strip Held

1 Which cable design was able to support the most weight? Why?

2 Which design could support the least? Why?

Days Four & Five K-8 Standard Alignment



- 7.T/E.1b Explain how tools are used to extend the senses, make life easier, and solve everyday problems.
- 7.T/E.1a Recognize that both natural materials and human-made tools have specific characteristics that determine their use.
- 7.T/E.2 Apply engineering design and creative thinking to solve practical problems.

These standards will be met and reinforced as students explore and learn about the history of rope and living bridges around the world, why and how they were made, their features, their purpose, their history, and their makers. We'll explore why they were replaced and why some still remain (and continue to be rebuilt). Students will then apply what they've learned while making and testing (and then remaking & retesting!) their own bridge cables using strips of newspaper.



- 7.T/E.1a Recognize that both natural materials and human-made tools have specific characteristics that determine their use.
- 7.T/E.1b Explain how tools are used to extend the senses, make life easier, and solve everyday problems.
- 7.T/E.2 Apply engineering design and creative thinking to solve practical problems.

These standards will be met and reinforced as students explore and learn about the history of rope and living bridges around the world, why and how they were made, their features, their purpose, their history, and their makers. We'll explore why they were replaced and why some still remain (and continue to be rebuilt). Students will then apply what they've learned while making and testing (and then remaking & retesting!) their own bridge cables using strips of newspaper.



- 7.T/E.1a Recognize that both natural materials and human-made tools have specific characteristics that determine their use.
- 7.T/E.1b Explain how tools are used to extend the senses, make life easier, and solve everyday problems.
- 7.T/E.2 Apply engineering design and creative thinking to solve practical problems.

These standards will be met and reinforced as students explore and learn about the history of rope and living bridges around the world, why and how they were made, their features, their purpose, their history, and their makers. We'll explore why they were replaced and why some still remain (and continue to be rebuilt). Students will then apply what they've learned while making and testing (and then remaking & retesting!) their own bridge cables using strips of newspaper.



- 7.T/E.1a Describe how tools, technology, and inventions help to answer questions and solve problems.
- 7.T/E.1b Explain how different inventions and technologies impact people and other living organisms.
- 7.T/E.5 Apply a creative design strategy to solve a particular problem, ex. one generated by societal needs and wants.

These standards will be met and reinforced as students explore and learn about the history of rope and living bridges around the world, why and how they were made, their features, their purpose, their history, and their makers. We'll explore why they were replaced and why some still remain (and continue to be rebuilt). Students will then apply what they've learned while making and testing (and then remaking & retesting!) their own bridge cables using strips of newspaper.



- 7.T/E.1a Describe how tools, technology, and inventions help to answer questions and solve problems.
- 7.T/E.1b Explain how different inventions and technologies impact people and other living organisms.
- 7.T/E.5 Apply a creative design strategy to solve a particular problem, ex. one generated by societal needs and wants.

These standards will be met and reinforced as students explore and learn about the history of rope and living bridges around the world, why and how they were made, their features, their purpose, their history, and their makers. We'll explore why they were replaced and why some still remain. Students will then apply what they've learned while making and testing (and then remaking & retesting!) their own bridge cables using strips of newspaper.



- 7.T/E.1a Describe how tools, technology, and inventions help to answer questions and solve problems.
- 7.T/E.1b Explain how different inventions and technologies impact people and other living organisms.
- 7.T/E.5 Apply a creative design strategy to solve a particular problem, ex. one generated by societal needs and wants.

These standards will be met and reinforced as students explore and learn about the history of rope and living bridges around the world, why and how they were made, their features, their purpose, their history, and their makers. We'll explore why they were replaced and why some still remain (and continue to be rebuilt). Students will then apply what they've learned while making and testing (and then remaking & retesting!) their own bridge cables using strips of newspaper.



- 7.T/E.1 Explore how technology responds to social, political, and economic needs.
- 7.T/E.2 Apply the engineering design process [an ongoing series of events that incorporate design constraints, model building, testing, evaluating, modifying, and retesting] to construct a prototype that meets certain specifications.
- 7.T/E.5 Develop an adaptive design and test its effectiveness.

These standards will be met and reinforced as students explore and learn about the history of rope and living bridges around the world, why and how they were made, their features, their purpose, their history, and their makers. We'll explore why they were replaced and why some still remain (and continue to be rebuilt). Students will then apply what they've learned while making and testing (and then remaking & retesting!) their own bridge cables using strips of newspaper.



- 7.T/E.1 Explore how technology responds to social, political, and economic needs.
- 7.T/E.2 Apply the engineering design process [an ongoing series of events that incorporate design constraints, model building, testing, evaluating, modifying, and retesting] to construct a prototype that meets certain specifications.
- 7.T/E.5 Develop an adaptive design and test its effectiveness.

These standards will be met and reinforced as students explore and learn about the history of rope and living bridges around the world, why and how they were made, their features, their purpose, their history, and their makers. We'll explore why they were replaced and why some still remain (and continue to be rebuilt). Students will then apply what they've learned while making and testing (and then remaking & retesting, and keeping track of data!) their own bridge cables using strips of newspaper.



- 7.T/E.1 Explore how technology responds to social, political, and economic needs.
- 7.T/E.2 Apply the engineering design process [an ongoing series of events that incorporate design constraints, model building, testing, evaluating, modifying, and retesting] to construct a prototype that meets certain specifications.
- 7.T/E.5 Develop an adaptive design and test its effectiveness.

These standards will be met and reinforced as students explore and learn about the history of rope and living bridges around the world, why and how they were made, their features, their purpose, their history, and their makers. We'll explore why they were replaced and why some still remain (and continue to be rebuilt). Students will then apply what they've learned while making and testing (and then remaking & retesting, and keeping track of data!) their own bridge cables using strips of newspaper.

Day 6: Weave-a-Rope

"The walls between art and engineering exist only in our minds." - Theo Jansen

The history of rope is one of those commonly overlooked and yet totally essential tools in human development. It's one of those objects that seems to have a debated past. Ropes (distinct from chords or strings) may have been used as early as 28,000 years ago, and the first rope-making tools were believed to belong to the Egyptians around 4,000 BC.

Regardless of the exact date of the first rope, we know that people have had the need to make cordage and rope for thousands of years. From simple string to hang household items, to ropes to rig the sails and mooring lines in ships, to the steel cables in modern suspension bridges. Through experimentation they learned to engineer stronger and longer lasting rope from different materials.



As we know, the Incas, and other cultures used natural fibers found within the local vegetation to build bridges. Roebling's invention of wire rope helped make possible some of the most important technological achievements of the industrial age: telegraphs and telephones, electrification, deep mines and big ships, elevators and airplanes.

Like weaving for ancient bridge builders...Finger-knitting is a really easy way to make something from nothing, though for us it will happen

pretty quickly, especially if you use a super-bulky yarn. And it is a fun and a great way to start students (even as young as 4) weaving & knitting. (And while this five-finger knitting is actually crochet and not knitting, the process is a wonderful experience of the mechanics of how a stitch is made.) After all, research shows that for a child's hands to become skillful is vital to their holistic development and that handwork supports literacy and numeracy skills later on. Steiner wrote of how 'knitting begets thinking'.

Option: Students can get fancy and do two colors at the same time, or braid three lengths of finger knitting together to make a nice thick rope.

Materials:

- Any yarn*
- Students



Image via MiaFoleyArt.blogspot.com. All Rights Reserved. Visit her site for fun Project ideas & inspiration.

*Tip: Super-bulky yarn is a good weight to start with. It's easy to work with on the fingers and your students will get something done pretty fast. And variegated yarn adds naturally to the fun.



Variations: It's fun to finger knit with cotton rope, strips of old t-shirts (ex. Make finger knitting bracelets from a jersey T-shirt—find instructions [here](#)), twine, cotton loom [loops](#), jute, or leather. You can even finger knit the rope you finger knit! Play around with it and see what happens!

Also, don't worry, it is totally normal for the finger knitting to curl as it goes. It curls into a tube.

Basic Finger Knitting Steps:

Images & Instructions via MarthaStewart.com. All Rights Reserved.

1. Slip the end of a ball of yarn between your thumb and index finger. Pinch to anchor the yarn as you knit. Then loop the yarn around your pinkie and weave it through your fingers.

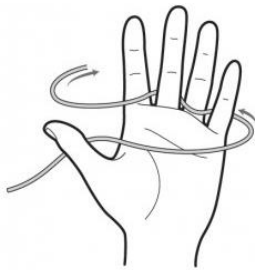

2. Loop the yarn around your index finger completely, and weave it toward your pinkie.

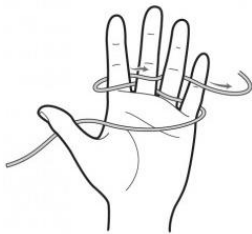

3. Make a full loop around your four fingers.

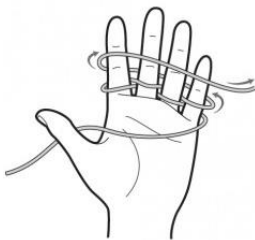

4. Slip the bottom (woven) row over the top (unwoven) row, from pinkie to index finger. Repeat steps 2 through 4 as the knitted side flows down the back of your hand to the desired length. To

cast off, cut the yarn, leaving about a 10-inch tail. Pull the yarn through all four loops, then pull the loops off your fingers. Tie the tail to the closest loop; trim.

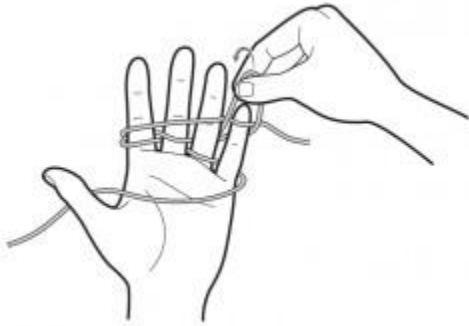

For some help & guidance: A clearly illustrated step-by-step guide from Flax & Twine is available (Option: purchase the Finger Knitting How-To PDF in the Flax & Twine Etsy shop [here](#) for \$2.50. Or, you can always just follow along with the photos and instructions [here](#)) A different tutorial from Maggie Whitely is [here](#)) and for those who are visual learners, there's a video tutorial from a different instructor available [here](#). She goes nice and slow and is very clear in her directions. Feel free to watch this if you need some guidance. **PRACTICE BEFORE WORKING WITH YOUR STUDENTS!**



EXTENSION IDEAS: Making most rope is easy, but the physics of ropes is fascinating! Research and discuss the development of rope-making technology through human history.

Rope is made of strands of material, like wire or fabric, which are each individually twisted in one direction, and then twisted or braided together in the opposite direction. The beauty of rope is that materials which are actually quite weak on their own, can be manipulated to be quite strong. As researchers stated in an article by Science News, it is a testament to the power of geometry.

The researchers found that in order to guarantee that the rope does not unwind, one must twist the individual strands of material to their maximum. This they call the "zero-twist point." They then measured ropes twisted to this point and found that in a triple stranded rope, the rope is 68% the length of the untwisted material.

Physicist Henrik Flyvbjerg of the Technical University of Denmark, who was not on the research team but is familiar with the work, agrees: The rule of the zero-twist point is universal.

"If there is life on other planets in other solar systems, their rope makers must follow the same rules," Flyvbjerg says.

Video Links: While students finger weave their ropes have them watch the fascinating 5min film [How It's Made--Rope](#) by Discovery Channel. The process from start to finish, with some testing too. And then have them compare and contrast that to Discovery and Science Channel's [How It's Made Industrial Wire Ropes](#) episode. Are the processes similar? Why or why not? Are the processes similar to how the rope is made for the Incan grass bridges? Why or why not?



Day Six: K-8 Standard Alignment

K

- 4.1.1 Recognize that art comes from different cultures, times, and places.
- 2.3.1 Recognize that art has a purpose.
- 2.4.2 Understand that art has a context.

These standards will be met and reinforced as we make our own ropes, learn to weave, and build upon what we've learned on previous days about artists/engineers throughout history in relation to bridges in general and woven/rope bridges in particular. We will determine that art can come in many forms, including the functional (aka ropes & bridges), and how different resources (ex. available materials, climate, weather, & terrain/obstacles to overcome) and cultures (context) shape its form and purpose. Students and instructors will also explore how engineers are artists as are other people (and art forms) that we may not always traditionally associate with art. We will compare what artist-engineers in the past created and how their work still influences modern bridge builders and rope makers (today's artist-engineers.)

1

- 4.1.1 Understand that art comes from different cultures, times, and places.
- 4.2.1 Understand that culture and history influence art.
- 2.3.1 Understand that art has a purpose.
- 2.4.1 Understand that art has a context.

These standards will be met and reinforced as we make our own ropes, learn to weave, and build upon what we've learned on previous days about artists/engineers throughout history in relation to bridges in general and woven/rope bridges in particular. We will determine that art can come in many forms, including the functional (aka ropes & bridges), and how different resources (ex. available materials, climate, weather, & terrain/obstacles to overcome) and cultures (context) shape its form and purpose. Students and instructors will also explore how engineers are artists as are other people (and art forms) that we may not always traditionally associate with art. We will compare what artist-engineers in the past created and how their work still influences modern bridge builders and rope makers (today's artist-engineers.)



- 4.1.1 Understand that art comes from different cultures, times, and places.
- 4.2.1 Understand that culture, history, and art influence one another.
- 2.3.1 Understand and apply purpose in art.
- 2.4.1 Understand and apply context in art.

These standards will be met and reinforced as we make our own ropes, learn to weave, and build upon what we've learned on previous days about artists/engineers throughout history in relation to bridges in general and woven/rope bridges in particular. We will determine that art can come in many forms, including the functional (aka ropes & bridges), and how different resources (ex. available materials, climate, weather, & terrain/obstacles to overcome) and cultures (context) shape its form and purpose. Students and instructors will also explore how engineers are artists as are other people (and art forms) that we may not always traditionally associate with art. We will compare what artist-engineers in the past created and how their work still influences modern bridge builders and rope makers (today's artist-engineers.)



- 4.1.1 Understand and demonstrate that art comes from different cultures, times, and places.
- 4.2.1 Understand and demonstrate how culture, history, and art influence each other.
- 2.5.1 Understand purpose in art.
- 2.7.1 Understand context in art.

These standards will be met and reinforced as we make our own ropes, learn to weave, and build upon what we've learned on previous days about artists/engineers throughout history in relation to bridges in general and woven/rope bridges in particular. We will determine that art can come in many forms, including the functional (aka ropes & bridges), and how different resources (ex. available materials, climate, weather, & terrain/obstacles to overcome) and cultures (context) shape its form and purpose. Students and instructors will also explore how engineers are artists as are other people (and art forms) that we may not always traditionally associate with art. We will compare what artist-engineers in the past created and how their work still influences modern bridge builders and rope makers (today's artist-engineers.)



- 4.1 Explore the relationship of art from different cultures, times, and places.
- 4.2 Examine and demonstrate how culture, history, and art influence one another.
- 2.5.1 Understand purpose in art.
- 2.7.1 Understand context in art.

These standards will be met and reinforced as we make our own ropes, learn to weave, and build upon what we've learned on previous days about artists/engineers throughout history in relation to bridges in general and woven/rope bridges in particular. We will determine that art can come in many forms, including the functional (aka ropes & bridges), and how different resources (ex. available materials, climate, weather, & terrain/obstacles to overcome) and cultures (context) shape its form and purpose. Students and instructors will also explore how engineers are artists as are other people (and art forms)

that we may not always traditionally associate with art. We will compare what artist-engineers in the past created and how their work still influences modern bridge builders and rope makers (today's artist-engineers.)



- 4.1.1 Explore the relationship of art from different cultures, time, and places.
- 4.2.1 Examine and demonstrate how culture, history, and art influence each other.
- 2.5.1 Evaluate purpose in art.
- 2.7.1 Evaluate context in art.

These standards will be met and reinforced as we make our own ropes, learn to weave, and build upon what we've learned on previous days about artists/engineers throughout history in relation to bridges in general and woven/rope bridges in particular. We will determine that art can come in many forms, including the functional (aka ropes & bridges), and evaluate how different resources (ex. available materials, climate, weather, & terrain/obstacles to overcome) and cultures (context) shape its form and purpose. Students and instructors will also explore how engineers are artists as are other people (and art forms) that we may not always traditionally associate with art. We will compare what artist-engineers in the past created and how their work still influences modern bridge builders and rope makers (today's artist-engineers.)



- RST.6-8.3. Follow precisely a multistep procedure when performing technical tasks.
- 4.1.1 Demonstrate an understanding of the historical and cultural contexts of artwork.
- 4.2.1 Demonstrate an understanding of the role of artists throughout history and cultures.
- 4.5.1 Reflect on how historical and cultural factors influence contemporary artwork and visual culture.

These standards will be met and reinforced as we make our own ropes, learn to weave, and build upon what we've learned on previous days about artists/engineers throughout history in relation to bridges in general and woven/rope bridges in particular. We will determine that art can come in many forms, including the functional (aka ropes & bridges), and evaluate how different resources (ex. available materials, climate, weather, & terrain/obstacles to overcome) and cultures (context) shape its form and purpose. Students and instructors will also explore how engineers are artists as are other people (and art forms) that we may not always traditionally associate with art. We will compare what artist-engineers in the past created and how their work still influences modern bridge builders and rope makers (today's artist-engineers.)



- RST.6-8.3. Follow precisely a multistep procedure when performing technical tasks.
- 4.1.1 Demonstrate an understanding of the historical and cultural contexts of artwork.
- 4.2.1 Demonstrate an understanding of the role of artists throughout history and cultures.
- 4.5.1 Reflect on how historical and cultural factors influence contemporary artwork and visual culture.

These standards will be met and reinforced as we make our own ropes, learn to weave, and build upon what we've learned on previous days about artists/engineers throughout history in relation to bridges in

general and woven/rope bridges in particular. We will determine that art can come in many forms, including the functional (aka ropes & bridges), and evaluate how different resources (ex. available materials, climate, weather, & terrain/obstacles to overcome) and cultures (context) shape its form and purpose. Students and instructors will also explore how engineers are artists as are other people (and art forms) that we may not always traditionally associate with art. We will compare what artist-engineers in the past created and how their work still influences modern bridge builders and rope makers (today's artist-engineers.)



- RST.6-8.3. Follow precisely a multistep procedure when performing technical tasks.
- 4.1.1 Demonstrate an understanding of the historical and cultural contexts of artwork.
- 4.2.1 Demonstrate an understanding of the role of artists throughout history and cultures.
- 4.5.1 Reflect on how historical and cultural factors influence contemporary artwork and visual culture.

These standards will be met and reinforced as we make our own ropes, learn to weave, and build upon what we've learned on previous days about artists/engineers throughout history in relation to bridges in general and woven/rope bridges in particular. We will determine that art can come in many forms, including the functional (aka ropes & bridges), and evaluate how different resources (ex. available materials, climate, weather, & terrain/obstacles to overcome) and cultures (context) shape its form and purpose. Students and instructors will also explore how engineers are artists as are other people (and art forms) that we may not always traditionally associate with art. We will compare what artist-engineers in the past created and how their work still influences modern bridge builders and rope makers (today's artist-engineers.)

Day 7: Spanning the Gaps! 500 Shakedown

Inspiration for this game via
mathgamesandactivities.com

Like bridges, students' math skills can be pretty shaky! One of the big skills students need to practice is subtraction at any level.

Kindergarteners through 6th graders find subtraction to be a challenge.

Here's a great double-digit subtraction game:

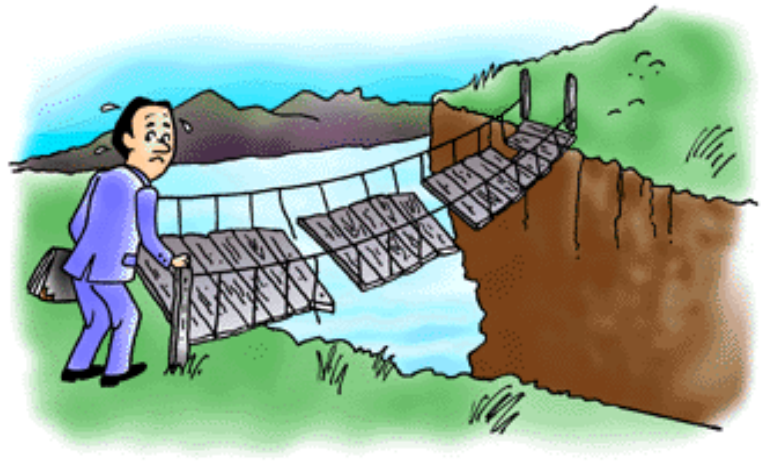

- What you need:
- 2 players
- 2 dice
- paper and pencil for each

Each player starts with 500 points (or another chosen amount determined by the instructor).

Player #1 rolls the dice and makes the biggest two-digit number he/she can. Now he/she subtracts this number from 500.

Example: Player #1 rolls a 2 and a 4 and makes 42. Now he/she subtracts 42 from 500.

Player #2 rolls the dice and does the same. Players continue to alternate turns. The first person to reach 0 wins.

There's only one complication! When you throw a 1, the rules change. You **don't** subtract. Instead you make the smallest two-digit number you can and add.

Example: If the player throws a 1 and a 5, the smallest two-digit number is 15. So he/she adds 15 to the total.

Variation: Start with 5,000 points and use three dice or start with 50,000 and use 4 dice.

500 Shake Down the Gap: Weeks 1 & 2

Player One	Player Two
500	500

First player to 0 wins!

Day Seven K-6 Math Skills

The following are selected from the comprehensive list of the math skills students learn in each grade. Remember, these skills build on each other. They are assuming that students have mastered all the ones in the previous grades.

The skills are organized into categories: As you read (and complete) the activities in the plan, keep in mind the specific skills your students need to practice and master in the different grade levels you work with. Use their needs to guide your approach in how you'll modify and present the activities and what specific tasks you will have the students do.



Subtracting

- J.1 Subtract with pictures - numbers up to 5
- J.2 Subtraction - numbers up to 5
- J.3 Subtraction sentences - numbers up to 5
- J.5 Subtract with pictures - numbers up to 10
- J.6 Subtraction - numbers up to 9
- J.7 Subtraction sentences - numbers up to 10



Subtraction

- D.1 Subtraction with pictures - numbers up to 10
- D.2 Subtraction sentences - numbers up to 10
- D.5 Ways to make a number using subtraction
- D.7 Ways to subtract from a number - subtraction sentences
- D.8 Subtracting zero and all
- D.9 Subtracting doubles
- D.10 Subtraction facts - numbers up to 10
- D.11 Subtraction facts - numbers up to 18
- D.16 Subtract tens
- D.17 Subtract one-digit numbers from two-digit numbers



Subtraction - one digit

- F.1 Review - subtract one-digit numbers - up to 10
- F.2 Review - ways to subtract - up to 10
- F.4 Subtract a one-digit number from a two-digit number up to 18
- F.5 Subtraction with pictures
- F.8 Subtract zero/all
- F.12 Balance subtraction equations - up to 18

Subtraction - two digits

- H.1 Subtract multiples of 10
- H.2 Subtract a one-digit number from a two-digit number - without regrouping
- H.3 Subtract a one-digit number from a two-digit number - with regrouping
- H.4 Subtract two two-digit numbers - without regrouping
- H.5 Subtract two two-digit numbers - with regrouping

- H.8 Ways to make a number using subtraction
- H.12 Balance subtraction equations - up to two digits

Subtraction - three digits

- J.1 Subtract multiples of 100
- J.2 Subtract three-digit numbers
- J.7 Balance subtraction equations - up to three digits



Subtraction

- D.1 Subtract numbers up to three digits
- D.4 Subtraction patterns over increasing place values
- D.5 Balance subtraction equations - up to three digits
- D.7 Subtract numbers with four or more digits



Subtraction

- C.1 Subtract numbers up to millions
- C.3 Subtraction: fill in the missing digits
- C.4 Subtraction patterns over increasing place values
- C.5 Choose numbers with a particular difference
- C.6 Estimate differences



Addition and subtraction

- D.1 Add and subtract whole numbers up to billions
- D.5 Complete addition and subtraction sentences
- D.6 Fill in the missing digits
- D.7 Choose numbers with a particular sum or difference
- D.8 Properties of addition
- D.10 Estimate sums and differences of whole numbers
- D.11 Estimate sums and differences: word problems



Add and subtract integers

- I.1 Review - add and subtract whole numbers
- I.3 Properties of addition
- I.4 Integer addition and subtraction rules
- I.7 Subtract integers - using counters
- I.8 Subtract integers



Operations with integers

- E.1 Integer addition and subtraction rules
- E.2 Add and subtract integers using counters
- E.3 Add and subtract integers



Operations with integers

- C.1 Integer addition and subtraction rules
- C.2 Add and subtract integers using counters
- C.3 Add and subtract integers
- C.4 Add and subtract three or more integers

Day 8: Feeling the Suspension?

Inform students that they'll want to pay CLOSE attention during the discussion as knowing facts and details from the discussion will help them (and their team) win during the competition to follow. Encourage them to take notes!

Suspension bridges such as San Francisco's Golden Gate Bridge (considered one of the top 10 engineering feats of the 20th century) and New York's Brooklyn Bridge are among the engineering wonders of the world today and owe a lot to those ancient grass bridges.

The properties of a suspension bridge are pretty straightforward. The decking is held up with the suspenders that are in constant tension (steel cable performs exceptionally well with tension and not compression like concrete) attached to the cables that are also in a fixed state of tension. These two are held up by the towers (also known as the pylons) that are



typically made of a concrete/ stone combination that fairs well in compression or steel structures that contain cross bracing to add stability and rigidity.

One of the major benefits of suspension bridges include the flexibility of these structures, making them ideal for earthquake-prone locations. However, this flexibility comes at a disadvantage in that it might vibrate more violently in strong winds.

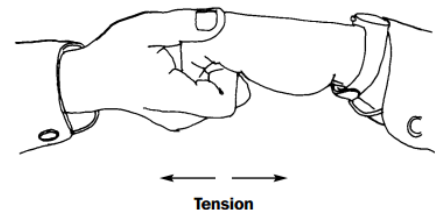
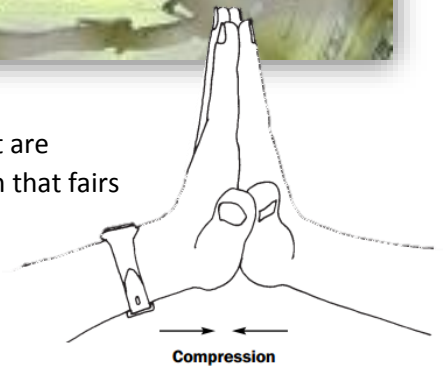

Did You Know?

The suspension bridge... can span 2,000 to 7,000 feet - way farther than any other type of bridge! Most suspension bridges have a **truss** system beneath the roadway to resist **bending** and **twisting**.

Suspension bridges are strong and can span long distances. They are expensive because they take a long time to build and require a large amount of material. They are commonly found across harbors with a lot of boat traffic. The primary elements of a suspension bridge are a pair of main cables stretching over two towers and attached at each end to an anchor. Smaller cables attached to the main cables support the roadway

Pros and Cons of Suspension Bridges

Pros: Spans distances up to 7,000 feet; considered attractive; allows large ships and heavy boat traffic to pass underneath

Cons: Expensive (requires a long time and a large amount of material to build)

Compression and Tension

Compression: Traffic pushes down on the roadway, but because it is suspended from the cables, the weight is carried by the cables, which transfer the force of compression to the two towers.

Tension: The force of tension is constantly acting on the cables, which are stretched because the roadway is suspended from them

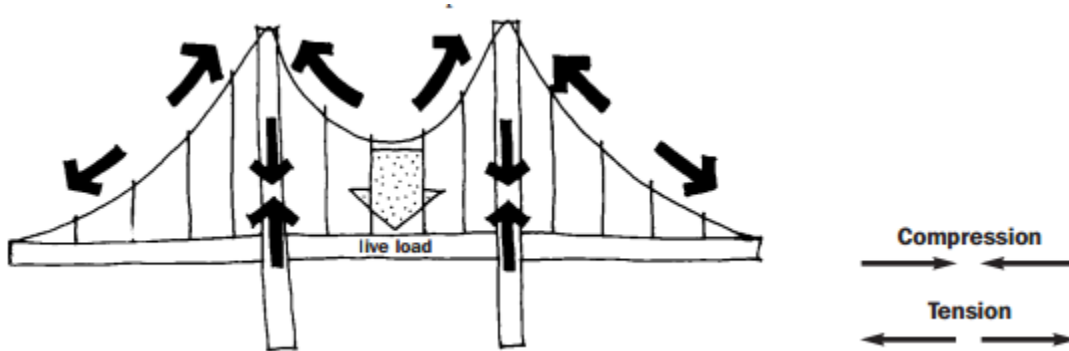

Golden Gate Bridge

Vital Statistics:

Location: San Francisco and Sausalito, California, USA

Completion Date: 1937

Cost: \$27 million

Length: 8,981 feet

Type: Suspension

Purpose: Roadway

Materials: Steel, concrete

Longest Single Span: 4,200 feet

Engineer(s): Joseph B. Strauss

They said it couldn't be built. Seventy-five years later, the Golden Gate Bridge has carried more than a billion cars across the San Francisco Bay. Today, some call it the "most spectacular bridge in the world." But a century ago, building the Golden Gate Bridge

seemed like an impossible task. Any bridge in this location would have to withstand brutal winds, tide, and fog. It would also sit less than eight miles from the epicenter of the most catastrophic earthquake in history. Only one engineer was willing to gamble



that his bridge could withstand such destructive power. His name was Joseph Strauss.

The bridge's original design, produced by chief engineer Strauss in 1921, was a clunky hybrid of a cantilever and suspension bridge that according to one critic resembled "an upside-down rat trap." It was functional, but far from elegant. Strauss agreed to scrap the design, and he later brought rival engineers onto the project to produce a more graceful suspension bridge design.



Strauss used more than one million tons of concrete to build the anchorages -- the massive blocks that grip the bridge's supporting cables. The north pier, which supports the tower, was built easily on a bedrock ledge 20 feet below the water. But on the southern San Francisco side, Strauss had to build his pier in the open ocean, 100 feet below the surface. He built a huge water-tight cofferdam -- big enough to enclose a football field -- and pumped in hundreds of tons of concrete. By 1935, the towers were complete, and cable-spinning began. Two years later, the bridge was finished.

In the 1930s, a rule of thumb on high-steel bridge construction projects was to expect one fatality for every \$1 million in cost. By those standards, the construction safety record for the \$35 million Golden Gate Bridge was impressive: only 11 construction workers died. (By contrast, 28 laborers died building the neighboring San Francisco-Oakland Bay Bridge, which opened six months prior.) Joseph Strauss made safety a high priority on the treacherous project. The chief engineer made the construction site the first in America to require workers to wear hard hats, and he spent \$130,000 on an innovative safety net that was suspended under the bridge deck. The net saved the lives of 19 workers, who called themselves the "Halfway to Hell Club." Ten of the 11 fatalities occurred in a single accident on February 17, 1937, when a 5-ton work platform broke apart from the bridge and fell through the safety net.

To pay for the bridge local citizens put their own properties up as collateral to finance construction of the Golden Gate Bridge. Little federal or state money was used to build the bridge. Most of the financing came from bonds sold by the Golden Gate Bridge and Highway District. Despite being in the midst of the Great Depression, voters in the district's six counties in 1930 approved a \$35 million bond issue that required them to put their homes, farms and businesses up as collateral. The resounding approval by a three-to-one margin reflected the faith of local citizens in the long-term economic benefit of the project. The construction bonds were retired in 1971.

Strauss completed the \$27 million bridge only five months after the promised date and \$1.3 million under budget. For his efforts, Strauss received \$1 million and a lifetime bridge pass.

A foghorn blared into the California dawn at 6 a.m. on May 27, 1937, to signal the official opening of the Golden Gate Bridge. That day, nearly 200,000 people ran, tap-danced and roller-skated across what was then the longest suspension bridge in the world.



The military wanted the Golden Gate Bridge to be painted in stripes.

The U.S. War Department initially objected to the construction of the Golden Gate Bridge because it feared that Navy ships could be trapped in San Francisco Bay if the span was bombed or collapsed. The military eventually gave its approval, but it wanted the bridge to be covered in garish stripes. The Navy, concerned about visibility for passing ships in foggy conditions, pressed for black and yellow stripes to be painted on the Golden Gate Bridge. The Army Air Corps pushed for a more festive, if not less gaudy, candy-cane combination of red and white stripes to make the bridge more noticeable from the air.

The Golden Gate Bridge's signature color was not intended to be permanent.

The steel that arrived in San Francisco to build the Golden Gate Bridge was coated in a burnt red and orange shade of primer to protect it from corrosive elements. Consulting architect Irving Morrow found that he preferred the vivid hue of the primer to more conventional paint choices such as carbon black and steel gray. The "international orange" color was not only visible in the fog, but it complemented the natural topography of the surrounding hills and contrasted well with the cool blues of the bay and the sky. Morrow ultimately selected the bold primer color, intended to be temporary, to coat the bridge. (The custom formula, manufactured by Sherwin-Williams, is no secret. It can be found on the bridge's web site.)

Here's how this bridge stacks up against some of the longest-spanning bridges in the world. (Total length, in feet)

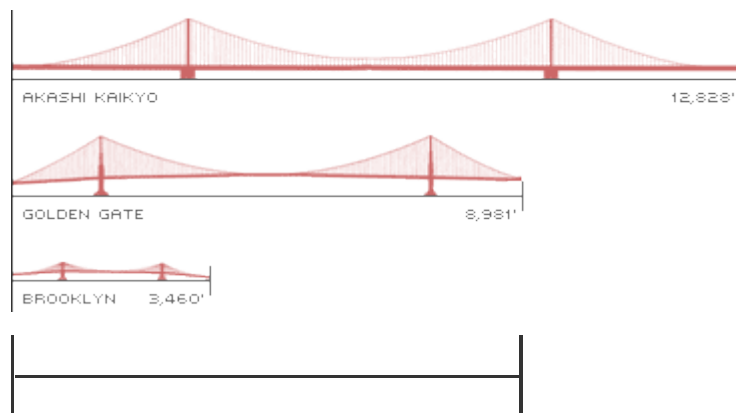

Golden Gate Bridge 8,981'

Fast Facts:

- The length of the steel wires used in the cables of the bridge is enough to circle the earth three times!
- If the U.S. Navy had its way, the bridge might have been painted in black and yellow stripes to assure greater visibility for passing ships.
- During construction, a safety net below the bridge saved the lives of 19 men who became known as the "Half-Way-to-Hell Club."
- More than one million cars have crossed the bridge since it opened in 1937.

Watch [Deconstructing History: Golden Gate Bridge](#) (4 min) TV-14 at [history.com](#) with students to get the facts about one of the world's most beautiful bridges.

Brooklyn Bridge

Vital Statistics:

Location: Manhattan and Brooklyn, New York, USA

Completion Date: 1883

Cost: \$18 million

Length: 3,460 feet

Type: Suspension

Purpose: Roadway

Materials: Steel, granite

Longest Single Span: 1,595 feet

Engineer(s): John A. Roebling, Washington A. Roebling



Click photo for larger image.

The Brooklyn Bridge opened to the public on May 24, 1883, thereby connecting Manhattan with Brooklyn for the first time. Dubbed the “Eighth Wonder of the World,” early visitors gawked at its immense granite towers and thick steel cables, not to mention its birds-eye views. The bridge, which took 14 years and over \$15 million to complete (more than \$320 million in today’s dollars), remains

among New York City’s top tourist attractions and a busy thoroughfare for commuters.

Considered a brilliant feat of 19th-century engineering, the Brooklyn Bridge was a bridge of many firsts. It was the first **suspension bridge** to use **steel** for its **cable** wire. It was the first bridge to use explosives in a dangerous underwater device called a caisson. At the time it was built, the 3,460-foot Brooklyn Bridge was also crowned the longest suspension bridge in the world.

A few high-profile collapses in the first half of the 19th century had prevented suspension bridges from immediately catching on. Undeterred, John A. Roebling

figured out how to stabilize them, largely by adding a web truss to either side of the roadway platform. He built four suspension bridges in the 1850s and 1860s, including one over the Ohio River and another near Niagara Falls. All would later be dwarfed by the Brooklyn Bridge was by far the longest suspension



Deconstructing History: Golden Gate Bridge

4min

bridge in the world. It remained that way until 1903, when the nearby Williamsburg Bridge overtook it by 4.5 feet.



But the Brooklyn Bridge was plagued with its share of problems. At least 20 people died during the bridge's construction.

German-born John A. Roebling, who designed the bridge if you remember, was taking compass readings one afternoon when his foot was crushed between some pilings and a boat. His toes were amputated, and a few weeks later he died of tetanus. Other workers fell off the 276-foot-high towers, were hit by falling debris or succumbed to caisson disease, better known as "the bends." No official figure exists for the number of men killed, but estimates range from 20 to over 30. The project was taken over and seen to its completion by Roebling's son, Washington Roebling. Dozens more suffered debilitating injuries, including Roebling's son Washington. Three years after his father died, Washington Roebling developed a crippling illness called caisson's disease, known today as "the bends." Bedridden but determined to stay in charge, Roebling used a telescope to keep watch over the bridge's progress. He dictated instructions to his wife, Emily, who passed on his orders to the workers. During this time, an unexpected blast wrecked one caisson, a fire damaged another, and a cable snapped from its **anchorage** and crashed into the river.

Despite these problems, construction continued at a feverish pace. By 1883, 14 years after it began, Washington Roebling successfully guided the completion of one of the most famous bridges in the world -- without ever leaving his apartment.

Huge crowds gathered on May 24, 1883, to watch the bridge's opening ceremony, which The New York Times described, in reference to Brooklyn, as "the greatest gala day in the history of that moral suburb." President Chester A. Arthur, New York Governor (and future president) Grover Cleveland and various local politicians marched onto the bridge, accompanied by a military band and an attachment of troops. Celebratory cannon fire rang out when they reached the Manhattan-side tower. The festivities also included an hour-long fireworks display, receptions and a number of speeches. Just before midnight the bridge opened to the public, and more than 150,000 people streamed across over the next 24 hours. Not everyone was happy, however. Many Irish boycotted the ceremony because it coincided with the birthday of British monarch Queen Victoria.



A tragedy occurred almost immediately.

A week after the opening, on Memorial Day, an estimated 20,000 people were on the bridge when a panic started, allegedly over a rumor that it was about to collapse. Twelve people were crushed to death on a narrow stairway, and others emerged bloodied and in some cases without clothes. One eyewitness described men and women "with their limbs contorted and their faces purpling in their agonized efforts

to breathe.” No changes came about in the immediate aftermath of the tragedy, except that more police were stationed on the pedestrian promenade.

The bridge toll was higher then than it is now.

When the Brooklyn Bridge first opened, it cost a penny to cross by foot, 5 cents for a horse and rider and 10 cents for a horse and wagon. Farm animals were allowed at a price of 5 cents per cow and 2 cents per sheep or hog. Under pressure from civic groups and commuters, the pedestrian toll was repealed in 1891. The roadway tolls were then rescinded in 1911 with the support of New York Mayor William J. Gaynor, who declared, “I see no more reason for toll gates on the bridges than for toll gates on Fifth Avenue or Broadway.” The Brooklyn Bridge and three other bridges that likewise cross the East River have stayed free ever since for both walkers and drivers, even as New York’s other major bridges and tunnels have gotten steadily more expensive.

At the time, the bridge connected two different cities.

Brooklyn did not become part of New York City until 1898, following a referendum that passed there by just 277 votes (out of more than 129,000 cast). Prior to the merger, it was the fourth most populous city in the country—behind only New York, Chicago and Philadelphia—with loads of manufacturing jobs, many churches, relatively low crime and good schools.

The bridge quickly became a cultural sensation.

The Brooklyn Bridge has arguably inspired more art than any other manmade structure in the United States. For almost a hundred and forty years it has inspired artists of all descriptions, fueling a constant stream of paintings, photographs, lithographs, etchings, advertising copy, movies, and book, magazine, and LP

covers. In consequence, the bridge may have the richest visual history of any man-made object, so much so, in fact, that almost no major American artist has failed to pay homage to the span in some form or other.



Georgia O’Keeffe, Andy Warhol and dozens of other well-known painters have incorporated it into their works, as have photographers (Walker Evans); documentarians (Ken Burns); playwrights (Arthur Miller); novelists (Henry Miller); newspaper columnists (Jimmy Breslin); urban historians (Lewis Mumford);

Art by Nina Boesch. Nina’s amazing collages are made entirely on MTA MetroCards, transformed into NYC’s most iconic images. Image Via: Subwayartblog.com Want to see more? Check out Nina’s website, MetroCard Yourself!

poets (Jack Kerouac); and musicians (Wyclef Jean). It likewise has had a slew of TV shows and movie cameos, including "The Docks of New York," "It Happened in Brooklyn," "Moonstruck," "Godzilla" and "Spider-Man." Meanwhile, advertisers have used the bridge to sell everything from Vaseline to Vodka, and it is even the symbol of an Italian chewing gum.

Option: Explore images from the book *Art of the Brooklyn Bridge: A Visual History* by Richard Haw with students.

The bridge has always attracted daredevils and showmen.

Circus entertainer P.T. Barnum took 21 elephants over the bridge in May 1884 to show that it was safe. The following year, Robert E. Odum, a swimming instructor from Washington, D.C., became the first to leap into the East River below. He died, but a number of later jumpers survived, including one man allegedly trying to impress his girlfriend and another who wore large canvas wings. Other stuntmen have flown planes under the bridge and bungee jumped from or climbed its towers.

Peregrine falcons nest atop it.

Peregrine falcons are the fastest animals on record, capable of reaching speeds over 200 miles per hour. They disappeared from the eastern United States due to DDT poisoning, but made a comeback after the pesticide was banned in 1972. Surprisingly, the birds soon began thriving in New York City, where they nest on bridges, church steeples and skyscrapers. Today, about 16 pairs of peregrines live in the Big Apple, and the Brooklyn Bridge has become one of their regular nesting sites.

Here's how this bridge stacks up against some of the longest-spanning bridges in the world. (total length, in feet)

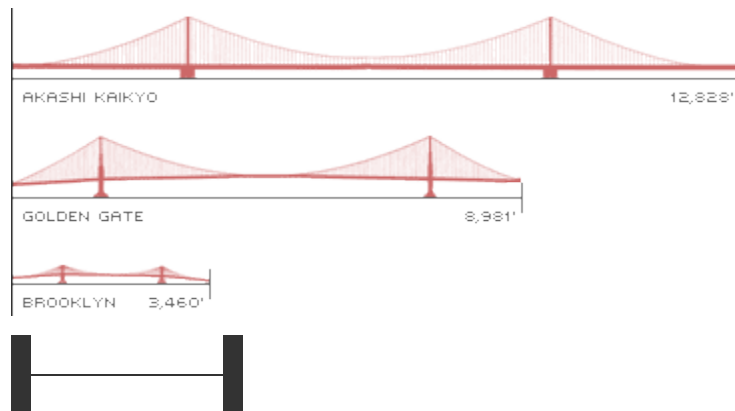

Brooklyn Bridge 3,460'

Watch the excellent videos [Deconstructing History: Brooklyn Bridge](#) (2 min) TV-14 and [The Brooklyn Bridge](#) (4 min) TV-PG from history.com with students to get the facts about one of the world's most

famous bridges.



Deconstructing History: Brooklyn Bridge
2min



The Brooklyn Bridge
4min

Fast Facts:

- Although he was physically able to leave his apartment, Washington Roebling refused to attend the opening celebration honoring his remarkable achievement.
- The bridge opened to the public on May 24, 1883, at 2:00 p.m. A total of 150,300 people crossed the bridge on opening day. Each person was charged one cent to cross.
- The bridge opened to vehicles on May 24, 1883, at 5:00 p.m. A total of 1,800 vehicles crossed on the first day. Vehicles were charged five cents to cross.
- Today, the Brooklyn Bridge is the second busiest bridge in New York City. One hundred forty-four thousand vehicles cross the bridge every day.

Something to Think About: Suspension bridges typically span longer distances than other types of bridges. Why do you think the New River Gorge Bridge, an arch bridge, spans a longer distance than the Brooklyn Bridge, a suspension bridge? Hint: Some things to consider might be the age of the bridge, technology, materials, and geographic site.

Scavenger Hunt Review

Activity inspired by an activity from Kara Wilkins & commentators @ toengagethemall.blogspot.com. All Rights Reserved. This is a great game for its simplicity, the minimal supplies, and the very minimal prep along with allowing for a really fun review. So, how do you play it?

1. Split your class into 5 or 6 teams, depending on how fast you want the game to go.
2. Each team gets 10 "X's" written up on the board, like in the example chart to the right.
3. Each group (either individual members rotating through—or the team as a whole) gets a question from the materials you just went through (ex. At the time of construction the Brooklyn Bridge connected what two cities? Or How many tons of concrete were used to build the Golden Gate Bridge's anchorages? & How much did it cost to cross the Brooklyn Bridge the first day it opened?) If they get it right they automatically get to erase two X's from the board. They can take it from one team or split it. They cannot take X's from themselves!

1	2	3	4	5
X	X	X	X	X
X	X	X	X	X
X	X	X	X	X
X	X	X	X	X
X	X	X	X	X
X	X	X	X	X
X	X	X	X	X
X	X	X	X	X
X	X	X	X	X
X	X	X	X	X

4. Before they take off these X's, though, they have a chance to increase their ability to get the other teams to 'carry a grudge.' They get to shoot the ball into the basket (ex. A clean wastebasket and paper wads also work well). Set up two lines with masking tape. One is a two point line (closer to the goal) while the other (farther back) is a three pointer.
5. They choose where they want to shoot from. If they shoot from the two point line and get it in, they can take four X's off the board. If they go from the three point line, and make it in, they can take five off the board. If they don't make it they still get to take the original two off the board.
6. When a team is knocked off they are still 'in the game'. These teams still take turns. To get back on the board they need to get the question right and make the basket. If they do this they can earn four or five X's back on the board (depending on from where they shoot). Getting back on the board is privilege enough, they can't remove X's until the next turn. This allows them to stay involved, take part in the review, and not shut down.
7. Play until there is one team standing or time runs out..... Whichever comes first! The winner is the last team with Xs on the board. If you run out of time it's the team with the most Xs.

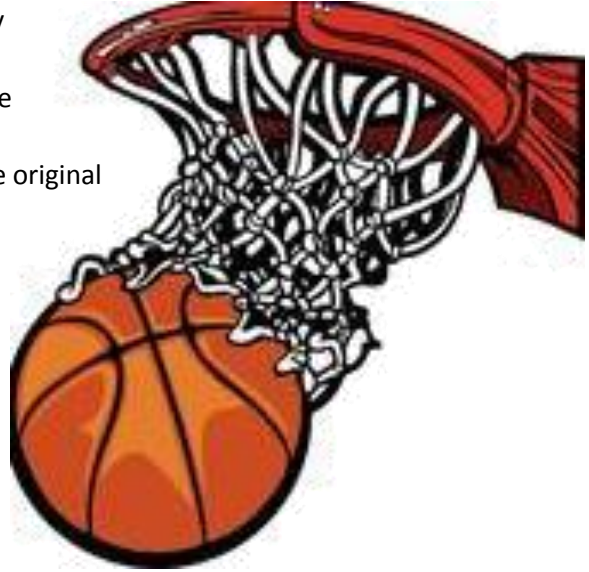

Notes: Kids will want to make alliances. With really good natured classes you may choose to let this process naturally happen. If you have an immature or meaner class, try to stop alliances from forming to prevent bullying of any kind. If there is a student who takes the "attacks" on their team personally, reiterate strongly that the object of the game is to knock everyone else off and people are going to get upset but that is okay (hence the name GRUDGE ball).

Tip: Use timers for classes (ex. 20 seconds) that take forever to answer.

Modification Ideas:

- ✓ If the team whose turn it is gets the answer to the question wrong, every other team has 30 seconds to try to get the correct answer to try to steal points. If any other team gets it correct, they get to shoot the basketball in order to see if they can steal 2 or 3 points from the teams of their choice. If they miss the shot, then they do not get to take away any points. It allows for the basketball to get shot more often, and it helps make sure every single team was participating in every problem.
- ✓ Have every student in every team write down the answer to each question. This will keep them all accountable. The motivation factor is that if the team up to bat gets the answer wrong, every team with the correct answer (written down by EVERY team mate) gets to add a point back to themselves
- ✓ To keep EVERYONE on each team engaged throughout the review, have one student at a time come to the front, hold the ball, and try to answer the question for two points before getting

the opportunity to take a shot and earn extra points. BUT if students can't answer the questions on their own, they can ask their teams to help them out with an answer, but then the point value of the original question drops to one point instead of two.

Day Eight K-8 Standard Alignment

K

- SL.K.3. Ask and answer questions in order to seek help, get information, or clarify something that is not understood.
- SL.K.2. Confirm understanding of a text read aloud or information presented orally or through other media by asking and answering questions about key details and requesting clarification if something is not understood.

These standards will be met and reinforced as students participate in the discussion and exploration of suspension bridges in general and the Brooklyn & Golden Gate Bridges specifically. We'll discuss facts and watch videos (comparing what they show to what we've talked about this day and on other days throughout the unit.) They will then use what they've learned to answer questions and continue their discussion during the review game.

1

- SL.1.3. Ask and answer questions about what a speaker says in order to gather additional information or clarify something that is not understood.
- SL.1.1. c) Ask questions to clear up any confusion about the topics and texts under discussion.

These standards will be met and reinforced as students participate in the discussion and exploration of suspension bridges in general and the Brooklyn & Golden Gate Bridges specifically. We'll discuss facts and watch videos (comparing what they show to what we've talked about this day and on other days throughout the unit.) They will then use what they've learned to answer questions and continue their discussion during the review game.

2

- SL.2.3. Ask and answer questions about what a speaker says in order to clarify comprehension, gather additional information, or deepen understanding of a topic or issue.
- SL.2.1. c) Ask for clarification and further explanation as needed about the topics and texts under discussion.
- RI.2.9. Compare and contrast the most important points presented by two texts on the same topic.

These standards will be met and reinforced as students participate in the discussion and exploration of suspension bridges in general and the Brooklyn & Golden Gate Bridges specifically. We'll discuss facts and watch videos (comparing what they show to what we've talked about this day and on other days throughout the unit.) They will then use what they've learned to answer questions and continue their discussion during the review game.

3

- SL.3.3. Ask and answer questions about information from a speaker, offering appropriate elaboration and detail.
- SL.3.1.d) Explain their own ideas and understanding in light of the discussion.

These standards will be met and reinforced as students participate in the discussion and exploration of suspension bridges in general and the Brooklyn & Golden Gate Bridges specifically. We'll discuss facts and watch videos (comparing what they show to what we've talked about this day and on other days throughout the unit.) They will then use what they've learned to answer questions and continue their discussion during the review game.



- SL.4.1 c) Pose and respond to specific questions to clarify or follow up on information, and make comments that contribute to the discussion and link to the remarks of others.
- SL.4.1 d) Review the key ideas expressed and explain their own ideas and understanding in light of the discussion.

These standards will be met and reinforced as students participate in the discussion and exploration of suspension bridges in general and the Brooklyn & Golden Gate Bridges specifically. We'll discuss facts and watch videos (comparing what they show to what we've talked about this day and on other days throughout the unit.) They will then use what they've learned to answer questions and continue their discussion during the review game.



- SL.5.1 c) Pose and respond to specific questions by making comments that contribute to the discussion and elaborate on the remarks of others.
- SL.5.1 d) Review the key ideas expressed and draw conclusions in light of information and knowledge gained from the discussions.

These standards will be met and reinforced as students participate in the discussion and exploration of suspension bridges in general and the Brooklyn & Golden Gate Bridges specifically. We'll discuss facts and watch videos (comparing what they show to what we've talked about this day and on other days throughout the unit.) They will then use what they've learned to answer questions and continue their discussion during the review game.



- SL.6.1. c) Pose and respond to specific questions with elaboration and detail by making comments that contribute to the topic, text, or issue under discussion.
- SL.6.1. d) Review the key ideas expressed and demonstrate understanding of multiple perspectives through reflection and paraphrasing.
- W.6.9. Draw evidence from literary or informational texts to support analysis, reflection, and research.

These standards will be met and reinforced as students participate in the discussion and exploration of suspension bridges in general and the Brooklyn & Golden Gate Bridges specifically. We'll discuss facts and watch videos (comparing what they show to what we've talked about this day and on other days throughout the unit.) They will then use what they've learned to answer questions and continue their discussion during the review game.



- SL.7.1 c) Pose and respond to questions that connect the ideas of several speakers and respond to others' questions and comments with relevant evidence, observations, and ideas.
- SL.7.1 d) Acknowledge new information expressed by others, and, when warranted, qualify or justify their own views in light of the evidence presented.
- SL.7.2. Analyze the main ideas and supporting details presented in diverse media and formats (e.g., visually, quantitatively, orally) and explain how the ideas clarify a topic, text, or issue under study.

These standards will be met and reinforced as students participate in the discussion and exploration of suspension bridges in general and the Brooklyn & Golden Gate Bridges specifically. We'll discuss facts and watch videos (comparing what they show to what we've talked about this day and on other days throughout the unit.) They will then use what they've learned to answer questions and continue their discussion during the review game.



- SL.8.1 c) Pose and respond to questions that connect the ideas of several speakers and respond to others' questions and comments with relevant evidence, observations, and ideas.
- SL.8.1 d) Acknowledge new information expressed by others, and, when warranted, qualify or justify their own views in light of the evidence presented.
- W.8.9. Draw evidence from literary or informational texts to support analysis, reflection, and research.

These standards will be met and reinforced as students participate in the discussion and exploration of suspension bridges in general and the Brooklyn & Golden Gate Bridges specifically. We'll discuss facts and watch videos (comparing what they show to what we've talked about this day and on other days throughout the unit.) They will then use what they've learned to answer questions and continue their discussion during the review game.

Sample Academic Vocabulary to Reinforce Weeks 1 & 2



- | | | |
|---------|---------|------------|
| • Job | • Tools | • Location |
| • Needs | • Parts | |



- | | | |
|------------|-----------|------------|
| • Property | • Invent | • Weight |
| • Push | • History | • Property |
| • Pull | • Length | |



- | | | |
|------------|---------------------|------------|
| • Type | • History | • Compare |
| • Distance | • Natural Resources | • Contrast |

- Landmark



- Landforms
- Natural resources



- Ancient civilizations
- Trade routes



- Region
- View
- Model



- Ancient
- Civilizations
- Empire



- Impact
- Topography



- Human impact
- Variation

- River

- Tools
- Force

- Expansion
- Weathering

- Core
- Gravity
- Solution

- Technological
- Cause
- Effect

- Speed
- Function

- Angles
- Tension

- Ancestor

- Exploration
- Remainder

- Reconstruct
- Historian

- Prototype
- Design Constraint

- Property
- Juncture

- Infrastructure
- Element

Sample Supply List Bridging the Gap Weeks 1&2

Day 1 & 2

- Access to videos & links
- Clay
- Ice Cube Trays: The ice cube tray has the perfect angles!
- Cardboard boxes
- Pieces of tube (ex. Mailing tubes, paper towel rolls, pvc, etc. Experiment to see what works best)
- Optional: masking tape or hot glue (in teacher control).
- Templates

Arching Higher Project:

- For a smaller arch between 16 to 25 feet in length - approximately 25 sheets of 4' x 5' cardboard,
- 200 lb. card stock B or C flute, bleached on one side, single corrugation (Comes in 5' x 8' sheets, which the supplier can cut in half for you. "Bleached" means that one face is white, which is ideal if you want to paint or decorate the finished arch).
- For a larger arch, 25 feet or more - approximately 50 5 x 8-foot sheets of 200 lb. double-wall cardboard. (This may not be available in "bleached.")
- Four or five rolls of 2-inch wide clear cellophane tape
- Several pairs of scissors
- Long metal straightedges
- Several sharp utility knives (Adults should be entrusted with the task of cutting)
- Pencils
- Paper (including graph-paper for the design phase)
- Compasses
- Rulers
- Tape measure
- Poster-board
- Length of twine or wire

Day 3

- Dice
- Paper or included worksheets (9 or 12 number variations are included)
- Pen/Pencil
- Markers or poker chips

Days 4 & 5

- Access to videos and links
- newspaper
- paper clips

- paper cups
- scissors
- tape
- stapler
- weights (such as washers, coins, books)
- various pieces of string, yarn, thread, twine, or rope
- hole puncher
- chairs
- sheets of paper
- Printout copies

Day 6

- Access to videos and links
- Thick/chunky yarn is recommended to start with but any kind will work

Variations: It's fun to finger knit with cotton rope, strips of old t-shirts (ex. Make finger knitting bracelets from a jersey T-shirt—find instructions [here](#)), twine, cotton loom [loops](#), jute, or leather. You can even finger knit the rope you finger knit! Play around with it and see what happens!

Day 7

- Dice
- Pencils
- Printouts

Day 8

- Access to videos and links
- Whiteboard markers/whiteboard
- List of questions formed from discussion/viewing materials
- Trash can & paperwads or basketball & hoop of some kind

SOURCES & REFERENCES

- https://en.wikipedia.org/wiki/simple_suspension_bridge#living_bridges
- http://www.makingthemodernworld.org.uk/learning_modules/maths/02.TU.03/?section=4
- <https://vimeo.com/118471437>
- <http://www.technologystudent.com/struct1/roman1.htm>
- <http://papermau.blogspot.com/2013/08/ancient-roman-aqueduct-paper-model-by.html>
- <http://toengagethemall.blogspot.com/2013/02/grudgeball-review-game-where-kids-attack.html>
- <http://www.mathgamesandactivities.com/fun-and-math-games/>
- <http://www.mathgamesandactivities.com/tag/math-games-in-the-classroom/>
- <http://www.history.com/news/6-things-you-may-not-know-about-the-golden-gate-bridge>
- <http://www.history.com/news/10-things-you-may-not-know-about-the-brooklyn-bridge>
- <http://www.history.com/search?q=Brooklyn%20Bridge>
- <http://www.attheworks.org/files/documents/Elmers%20Bridges%20Teaching%20Guide.pdf>
- <http://www.atlasobscura.com/places/root-bridges-cherrapunjee>
- http://www.slate.com/blogs/atlas_obscura/2013/06/10/the_last_incan_suspension_bridge_is_made_entirely_of_grass_and_woven_by.html
- <http://babakoto.eu/Articles/India/Che...>
- <http://www.cherrapunjee.com/rootbridg...>
- <http://www.indiabeat.co.uk>
- <http://www.cherrapunjee.com..>
- <http://www.smithsonianmag.com/smithsonian-institution/inca-rope-bridge-built-span-national-mall-washington-dc-180955609/?no-ist>
- <http://www.marthastewart.com/1042306/finger-knitting-fun>
- <http://miafoleyart.blogspot.com/2011/10/zen-of-finger-knitting-pair-of-hands.html>
- <http://www.boardgamecentral.com/rules/shut-the-box-rules.html>
- <http://www.history.com/topics/golden-gate-bridge>
- http://www.pbs.org/wgbh/buildingbig/wonder/structure/akashi_kaikyo.html
- http://www.pbs.org/wgbh/buildingbig/wonder/structure/sunshine_skyway.html
- http://www.pbs.org/wgbh/buildingbig/wonder/structure/chesapeake_bay_brdg.html
- http://www.pbs.org/wgbh/buildingbig/wonder/structure/golden_gate.html
- <http://www.pbs.org/wgbh/buildingbig/bridge/index.html>
- <https://www.cantonart.org/media/1/5/geo13.pdf>
- http://www.glencoe.com/sites/common_assets/art/studio_lessons/roman_arch.htm
- <http://wiseschool.weebly.com/project-studio1/building-sumerian-arches>
- http://www.mtbikewnc.com/gallery/daniel-ridge-loop-ride/2003-04-25_pisgah-davidson-river_daniel-ridge-trail-old-log-bridge
- <http://www.whatmuseum.org/photo-archives/category/1-darius-kinsey>
- <http://lejog947.co.uk/?p=193>
- <http://flick-the-thief.deviantart.com/art/Troll-bridge-138722067>
- <http://www.garrettsbridges.com/aboutme/>
- <http://www.pbslearningmedia.org/resource/phy03.sci.phys.mfw.bbarch/arch-bridge/>

ALL MATERIALS USED FOR PERSONAL, EDUCATIONAL, AND OTHER NON-COMMERCIAL USE ONLY.